

Atlas Copco



**Dry technology.
Made simple.**

DSS 065-100

Dry Scroll vacuum pump

We believe in dry technologies

At Atlas Copco, customer focus is a key factor of our success. When we contribute to the productivity of our customers, it propels us forward and is the driving force in everything we do.

One of the hallmarks of customer-focused innovation is simplicity. A vacuum pump that offers lower lifecycle costs, higher productivity, less energy consumption, simple operation and control and also easy maintenance.



DSS Scroll vacuum pump

The Atlas Copco DSS scroll vacuum pump is a noteworthy addition to Atlas Copco's formidable industrial dry pump range. With only one moving part and oscillating scroll design, the all-aluminum construction of the DSS scroll vacuum pump is robust, oil-free, highly efficient and low maintenance.

Ideal for vacuum generation across the rough vacuum range, it is a welcome fit to any production floor due to its simple and elegant design. It is a dry and durable pump for stable vacuum at low to medium flow rates working from atmospheric pressure to 1.5 mbar(a) 1.13 Torr.

The DSS is available in:

DSS 065 - 72m³/hr (42cfm) pumping speed @50Hz and 86m³/hr (51cfm) pumping speed@60Hz

DSS 100 - 100m³/hr (59cfm) pumping speed @50Hz



Design and internal mechanism

The mechanism of a scroll vacuum pump uses two interleaved spiral-shaped scrolls or spirals to pump gases. The design is simple, yet effective. One of the scrolls is fixed, while the other orbits without oscillating, thereby compressing pockets of gas between the scrolls. The Atlas Copco DSS scroll vacuum pump operates on the same principle.

With only one moving part and manufactured with high quality materials, the pump is a low-maintenance machine with an extended lifetime.

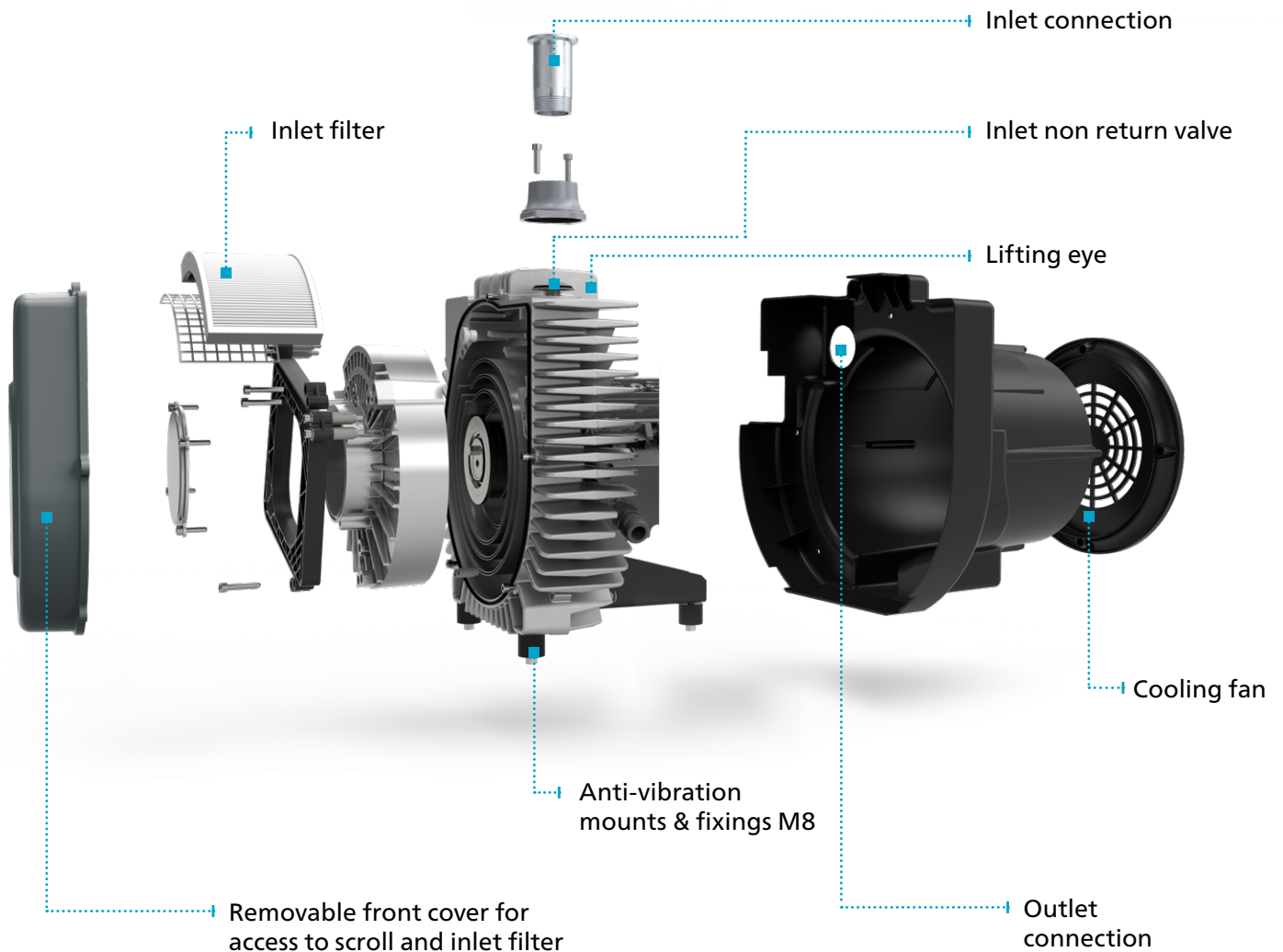
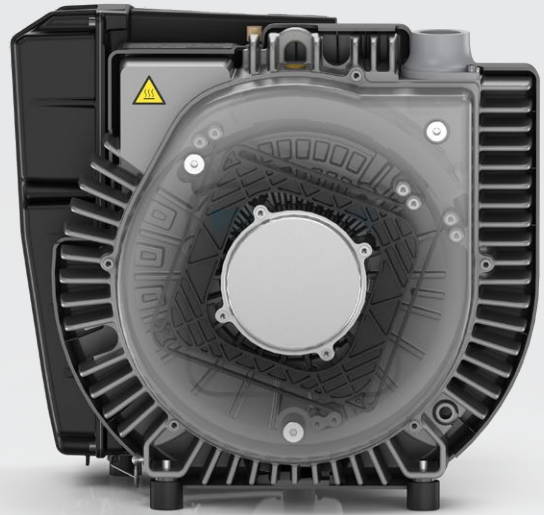

Features and benefits



Clean

- Class 0 certified according to ISO 8573-1
- Dry and oil-free vacuum technology
- No oil required for sealing or cooling
- No touching parts, oil filters or exhaust filters



Performance

- Complete controllability with the ability to be inverter driven
- Unique gas porting and gas ballast features
- Low service and maintenance costs



Robust design

- Simple, clean and modern design that is compact and rugged
- Removable front cover for access to scroll and inlet filter
- Inlet non-return valve

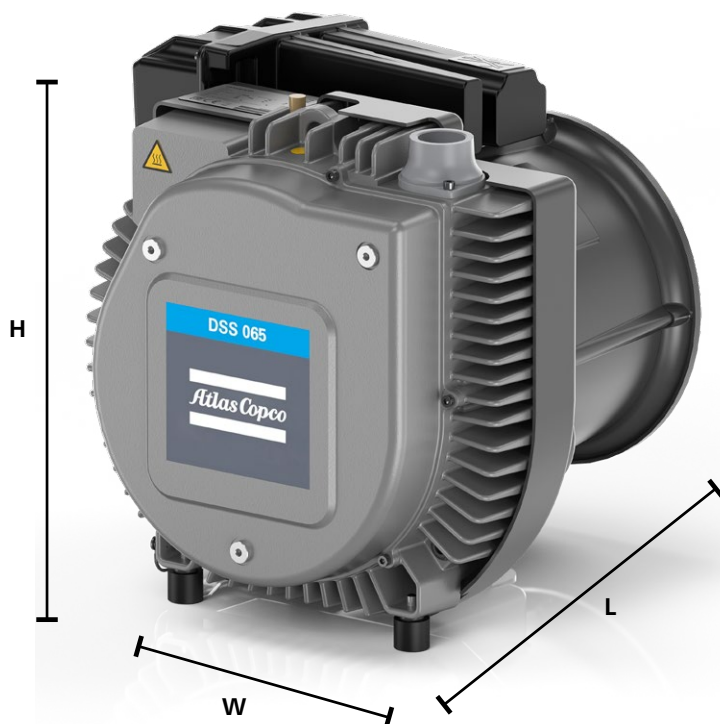

Dimensions



	DSS 065	DSS 100
Length (mm/inch)	446/17.5	446/17.5
Width (mm/inch)	488/19.2	488/19.2
Height (mm/inch)	435/17.1	435/17.1

Applications

- Food packaging
- Thermoforming
- Food processing
- Food drying
- Medical systems
- Vacuum impregnation
- Central house vacuum
- Pick and place
- CNC clamping
- Laboratory vacuum

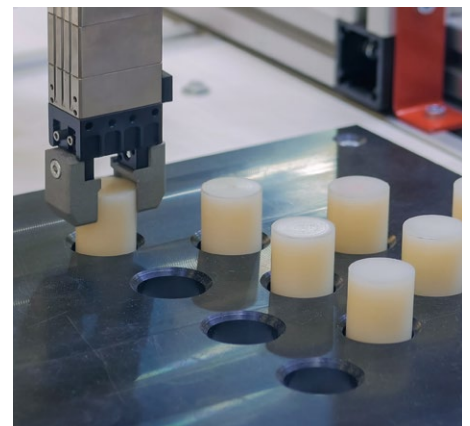
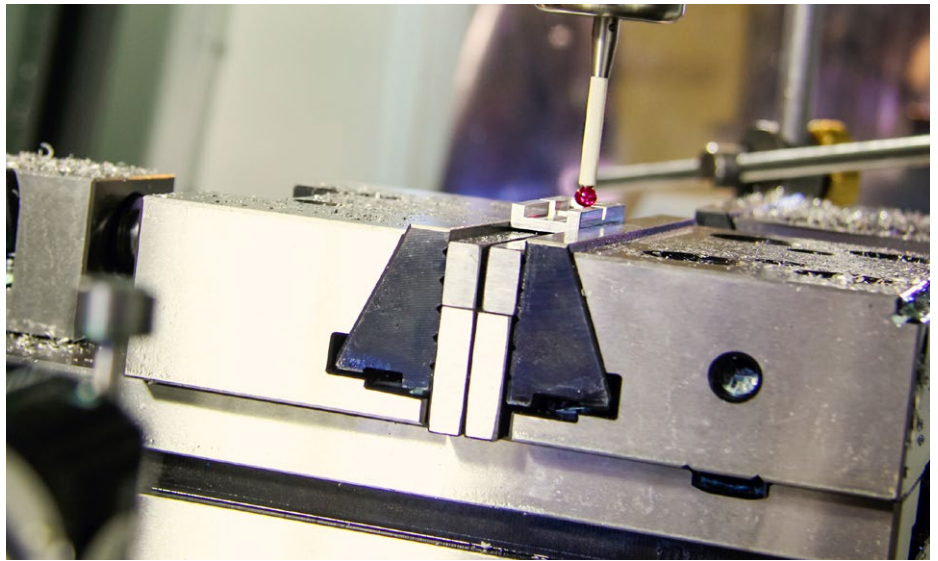

Technical drawings

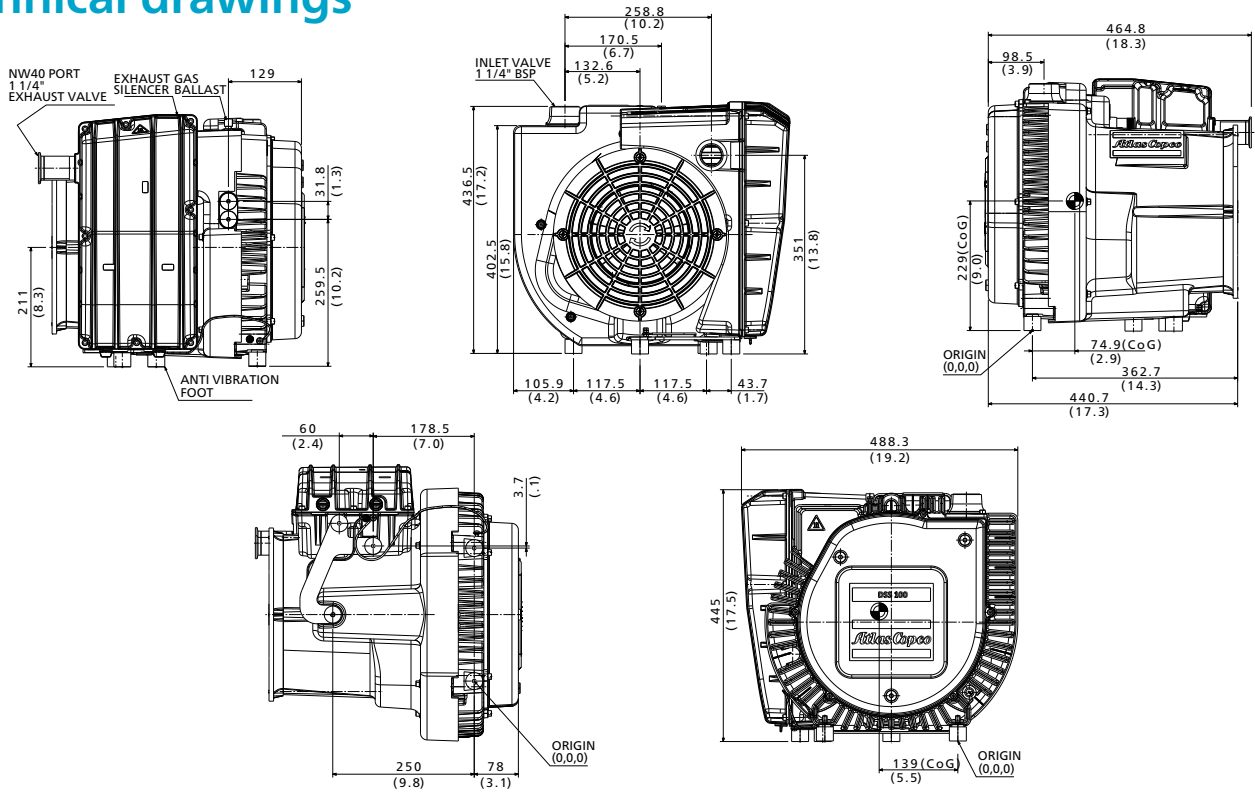

Performance curves

DSS 065

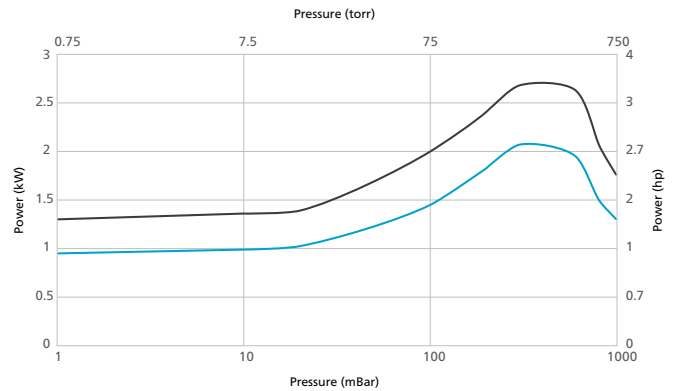
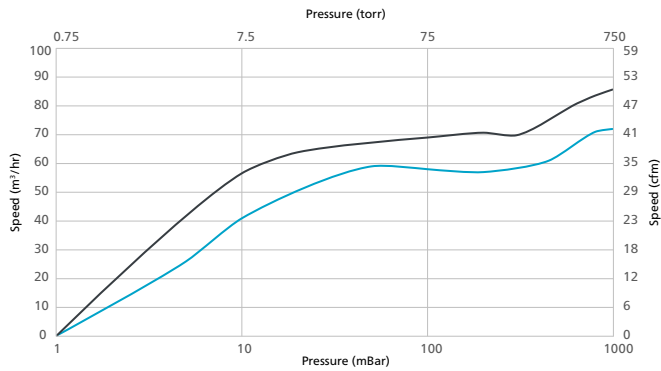

DSS 100

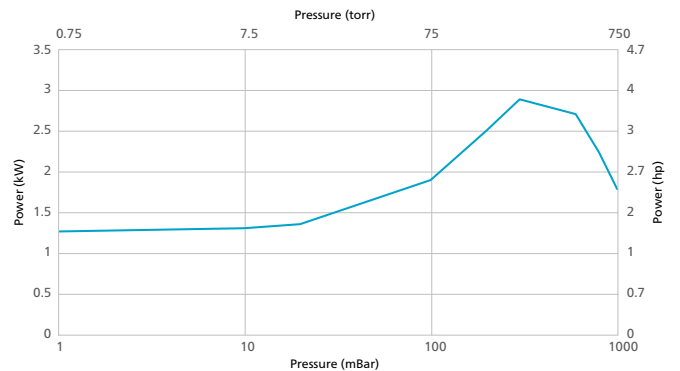
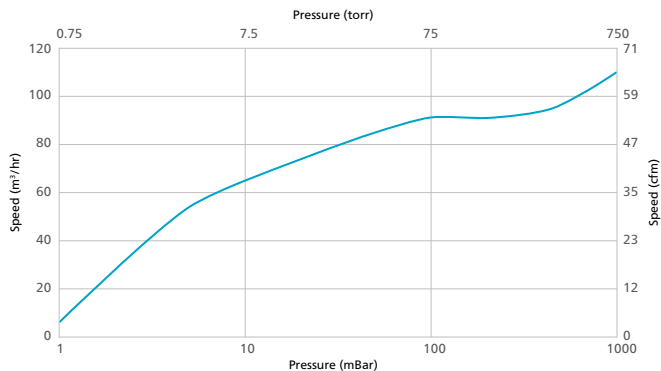

— @50Hz — @60Hz

Technical specifications

		DSS 065		DSS 100
	Units	50Hz	60Hz	50Hz
Max pumping speed	m ³ /h	72	86	100
Max pumping speed	acfm	42	51	59
Ultimate vacuum level	mbar/torr	1.5/1.13	1.5/1.13	1.5/1.13
Nominal motor power	kW	1.5	2.2	2.2
Nominal motor power	hp	2	3	3
Inlet	inch	G 1 ¼"	G 1 ¼" or NPT	G 1 ¼"
Outlet	inch	G 1 ¼"	G 1 ¼" or NPT	G 1 ¼"

Service support and maintenance



Complete service with our Preventive Care plan

We take over the maintenance planning and responsibility for servicing your vacuum pump on a regular basis. Our Preventive Care plan is tailored to your pump's needs. As your pump is serviced with the latest technology, high levels of energy efficiency are achieved. We will also optimize service events to reduce your total cost of ownership and increase your productivity. This allows you to focus fully on your production.



Maximize lifetime of your vacuum pumps

Our vacuum specialists are well-trained and experts in the field. They will help you to improve uptime and protect your processes. Regular maintenance conducted by one of our vacuum specialists reduces the risk of deterioration. Damaged or worn parts will be replaced with genuine Atlas Copco spare parts to protect your investment and increase the lifespan of your vacuum pumps.



Cost-effective approach

Regular scheduled maintenance can identify potential problems before they occur and plans can be structured around your individual production situation. Preventive Care enables cost management as you can plan your maintenance costs in advance. In this way, expenses associated with unplanned downtime are minimized.



Reliability meets non-stop productivity

We use genuine Atlas Copco spare parts and oil and our services are conducted by vacuum specialists according to manufacturer's recommendations. This enhances your vacuum pump performance, reducing the risk of downtime and enabling your production to run more smoothly.

Your Local Sales Professional:



Connect with us online:

www.nwflowtech.com

info@nwflowtech.com

Northwest Flow Technologies | Engineering Services

ID, MT & WY: (208) 360-3833

62 W 465 N, #3

Blackfoot, ID 83221

The Atlas Copco logo, consisting of the brand name "Atlas Copco" in a white, italicized, serif font, centered between two horizontal white bars.

Atlas Copco AB

atlascopco.com

