

# END-SUCTION CENTRIFUGAL PUMPS

Series: BCS  
0.75 - 3 HP @ 3500 RPM  
0.5 HP @ 1750 RPM  
1 & 3 phases



## SUCTION

1¼" or 1½" NPT horizontal.

## DISCHARGE

1" or 1¼" NPT vertical.

## SPHERICAL SOLIDS HANDLING

Up to 3/8" diameter.

## MAX. WORKING PRESSURE

175 PSIG.

## MAX. TEMPERATURES

250°F (121°C).

## BODY

AISI 316 stainless steel.

## INTERMEDIATE COUPLING

Cast iron.

## IMPELLER

**Design:** open.

**Material:** AISI 316 stainless steel.

## SEAL

**Design:** mechanical, type 01.

**Material:** carbon/silicon-carbide faces, Viton elastomers and 316 stainless steel metal parts.

## SEAL PLATE

AISI 316 stainless steel.

## SHAFT SLEEVE

AISI 316 stainless steel.

## O-RINGS

Viton.

## MOTOR

NEMA standard 56J frame motors from 0.75 to 3 HP at 3500 RPM and 0.5 HP at 1750 RPM. Open drip-proof and totally enclosed fan-cooled.

Single phase 115/230 V (3 HP model is 230 V only). Built in overload with auto reset provided. Three phase 208-230/460V.

Overload protection must be provided.

## HARDWARE

AISI 304 stainless steel.

## PAINT

Solvent based enamel (only intermediate coupling).

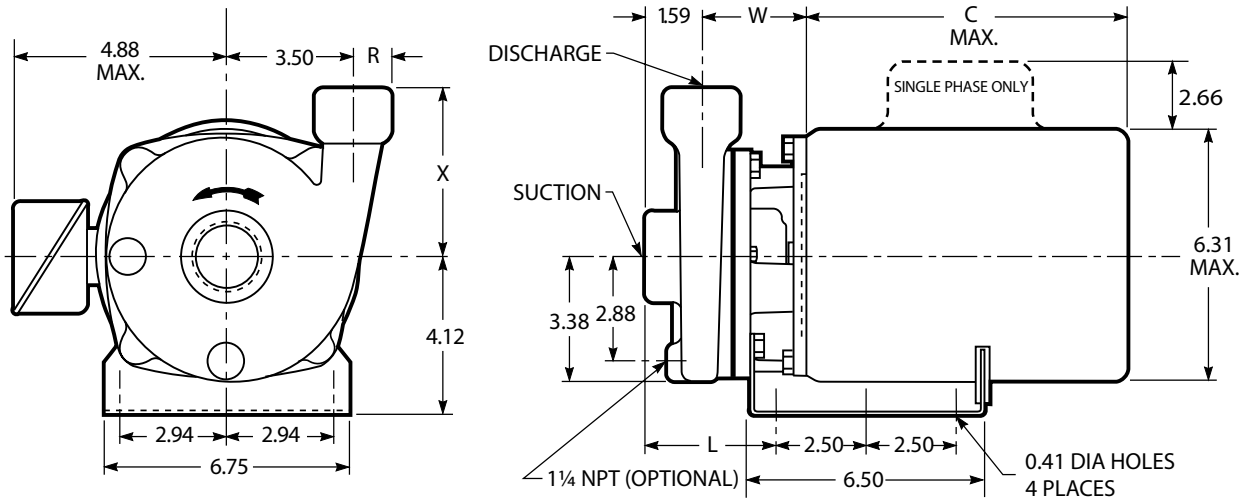

DIMENSIONS IN INCHES

**Dimensions and Weights – Determined by Pump**

MODEL	SIZE	DIMENSIONS				WEIGHT MAX. OF PUMP
		L	R	W	X	
BCS 1 x 1¼-5	1 x 1¼	3.75	0.94	3.01	4.62	17
BCS 1¼ x 1½-5	1¼ x 1½	3.62	1.06	2.88	4.56	17

**Available Motor Weights and Dimensions**

HP	SINGLE PHASE		THREE PHASE		C MAX. LENGTH
	ODP	TEFC	ODP	TEFC	
0.5	16	21	19	18	10.5
0.75	19	24	21	21	11
1	22	26	23	21	11.38
1.5	28	35	27	27	12.06
2	33	39	32	33	13
3	38	47	36	42	14

**NOTES:**

1. Pumps will be shipped with top vertical discharge as standard, for other orientations, remove casing bolts, rotate to desired position, and tighten 3/8" bolts to 24 lbf-ft.
  2. Dimensions in inches, weight in pounds.
  3. Not to be used for construction purposes unless certified.
  4. Motor dimensions may vary with motor manufacturers.
- \*Weight is liquid end only. For complete pump, add weight of applicable motor.**

**IMPORTANT!**

1. Never use this pump to handle explosive liquids.
2. This pump is not approved to be used in swimming pools, recreational installations or any application where human contact may be common.
3. Testing is performed with water specific gravity of 1.0 @ 68°F (20°C); other fluids may vary performance.

**PERFORMANCE CURVE**  
End-suction Centrifugal  
Stainless Steel Pumps  
Series: **BCS**

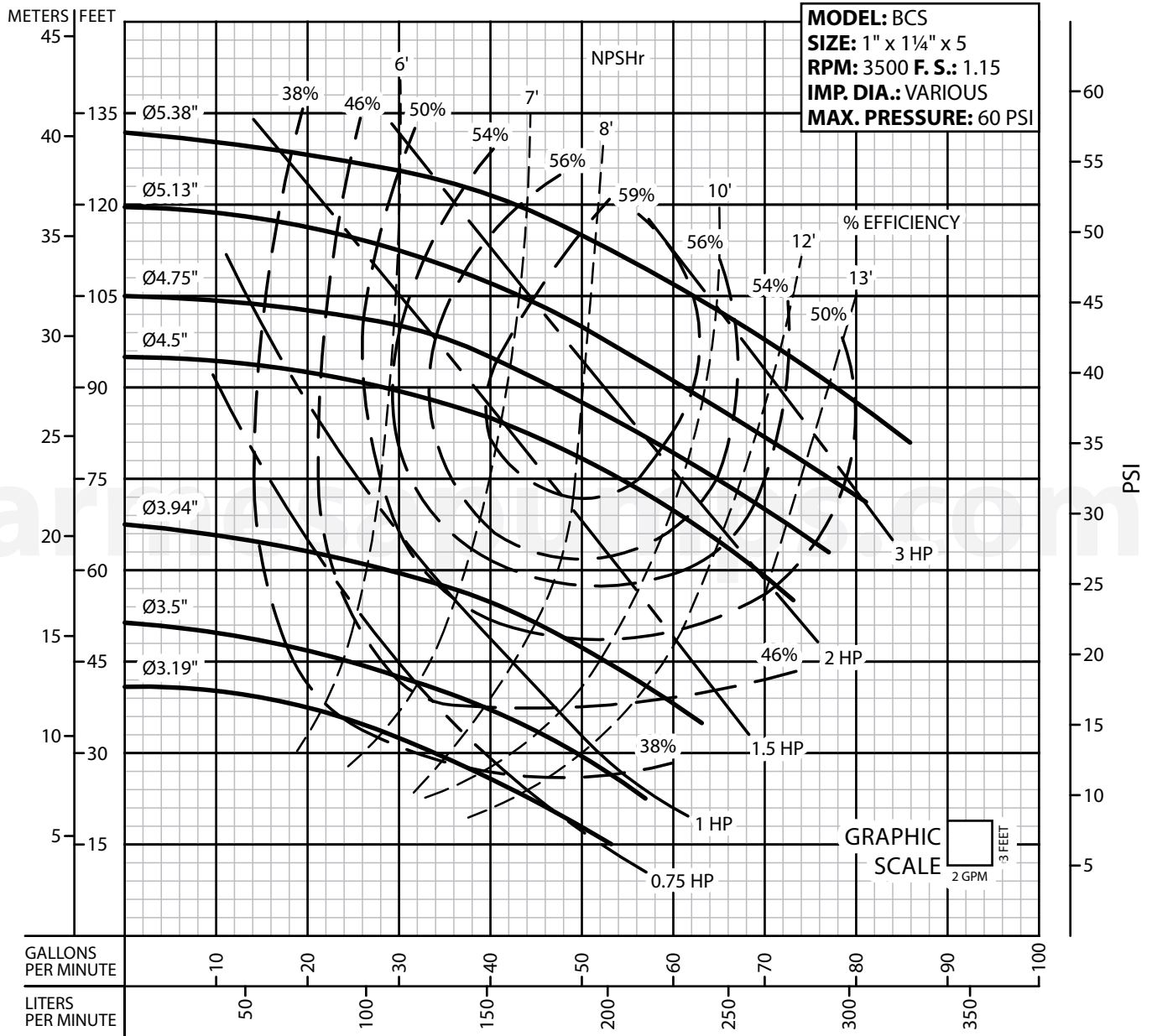

**PERFORMANCE CURVE**  
End-suction Centrifugal  
Stainless Steel Pumps  
Series: **BCS**

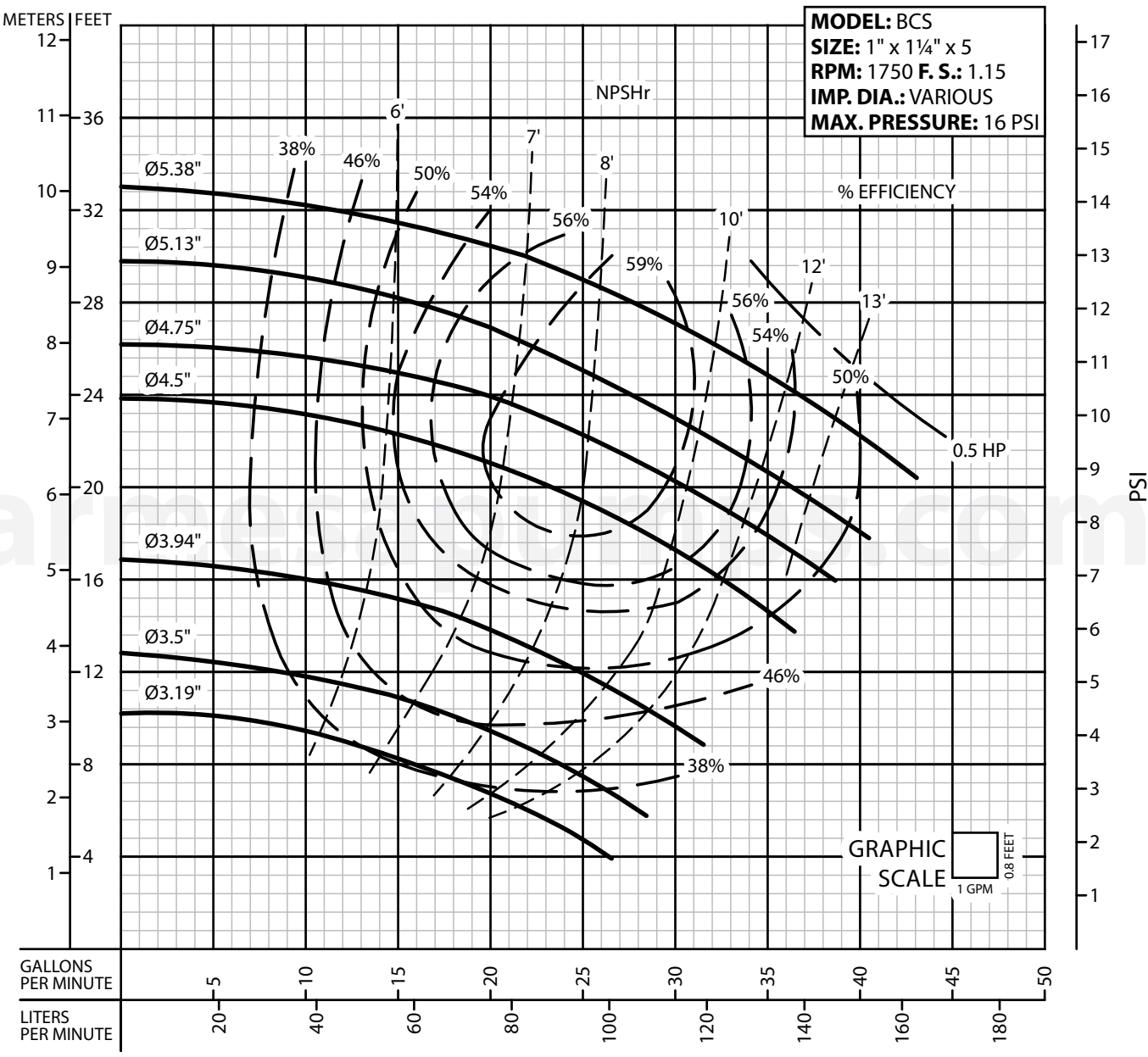

**PERFORMANCE CURVE**  
End-suction Centrifugal  
Stainless Steel Pumps  
Series: **BCS**

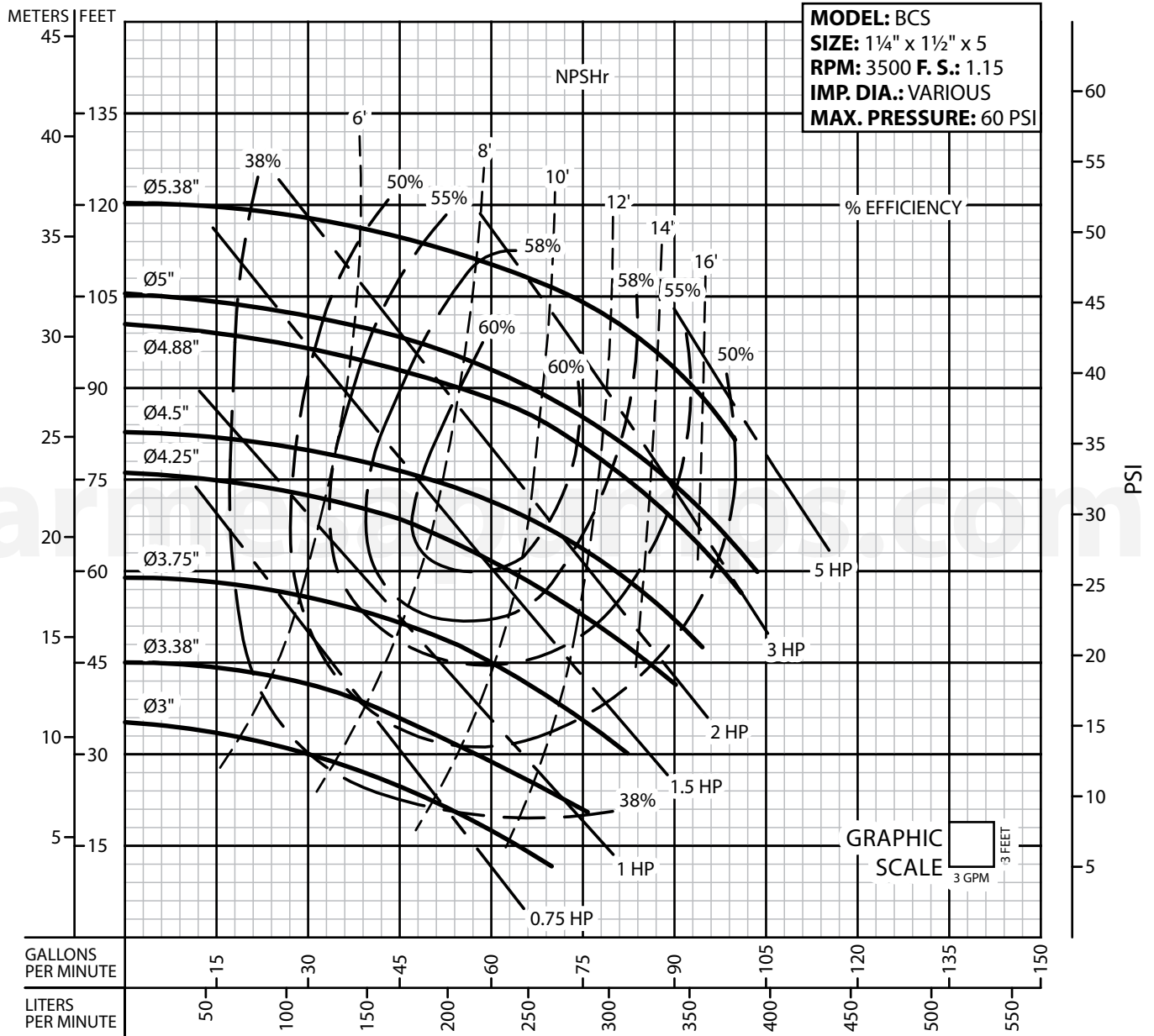

**PERFORMANCE CURVE**  
End-suction Centrifugal  
Stainless Steel Pumps  
Series: **BCS**

