

## Models

KT-150C    KT-300D    KT-500D    KT-850D

## Features

- Full pumping speed down to 1 Torr
- Can operate continuously (at any pressure) up to 100 Torr
- Ultimate pressure 10 Microns (McLeod Gauge)
- Adjustable gas ballast permits handling of condensable vapors
- No metal to metal contact in pumping chamber
- Unequaled durability, even in dirty applications
- Compact footprint design
- Simple installation, no special preparations required
- Triplex piston design provides quiet, vibration-free operation
- Integral, positive lubrication system ensures reliable lubrication at all pressure levels
- Optional factory-mounted oil filtration system lowers maintenance costs and increases uptime



## Specifications

	MODEL	KT-150C	KT-300D	KT-500D	KT-850D
Nominal Displacement	CFM / m <sup>3</sup> /h	150 / 255	300 / 510	500 / 850	778 / 1322
Motor	HP / kW	7.5 / 6	15 / 11	30 / 22	40 / 30
Cooling Water @ 60° F(15.5°C) – 45 psig max	GPM / L/min	1 / 4	1.5 / 8	3 / 12	4 / 16
Oil Capacity	gal / Liters	6 / 23	10 / 38	15 / 57	28 / 106
Pump Weight	Lbs. / kg	800 / 364	1525 / 693	2625 / 1200	4175 / 1900
Maximum Gas Ballast (GB) Flow	CFM / m <sup>3</sup> /h	11 / 18	20 / 34	34 / 58	62 / 105
Blank off (at 5% Gas Ballast)	Torr / mbar	2.0 / 2.6	2.0 / 2.6	2.0 / 2.6	2.0 / 2.6
Ultimate Pressure	Torr / mbar	0.010 / 0.013	0.010 / 0.013	0.010 / 0.013	0.010 / 0.013
Noise Level at 0.1 Torr	dB(A)	71	72	73	75

## Typical Pumping Speed Curves

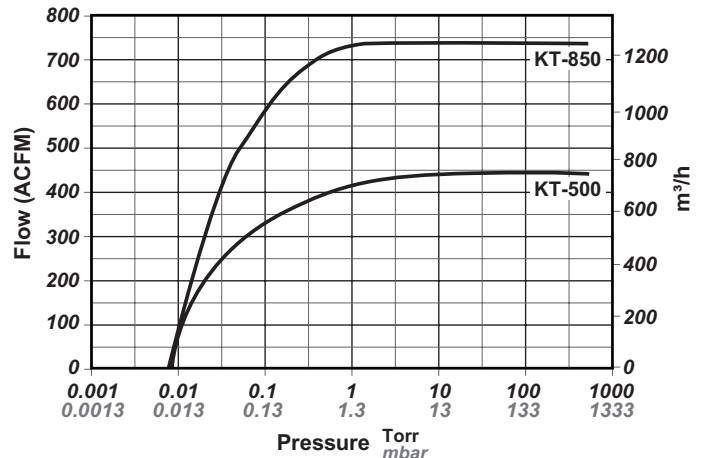
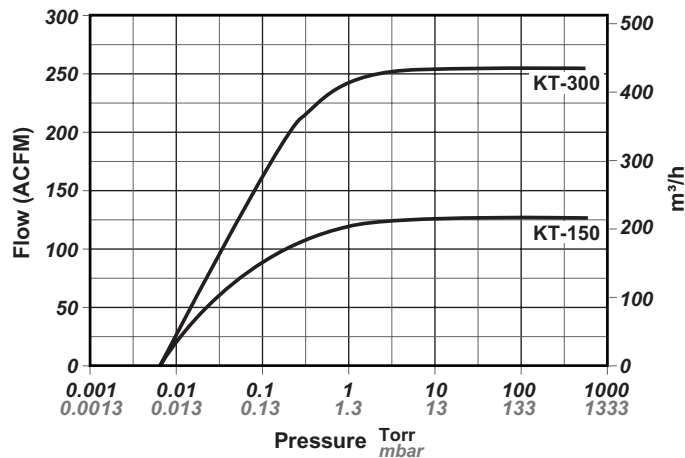

## Dimensions

Values shown are approximate and should not be used for construction.

Certified drawings are available through your local Tuthill Vacuum & Blower Systems Sales Professional.

## Models KT-150C, KT300D, KT-500D, KT-850D

KT-150C Note: Illustration does not accurately reflect features of KT-150C.

Water Inlet is position R and Water Outlet is position P.

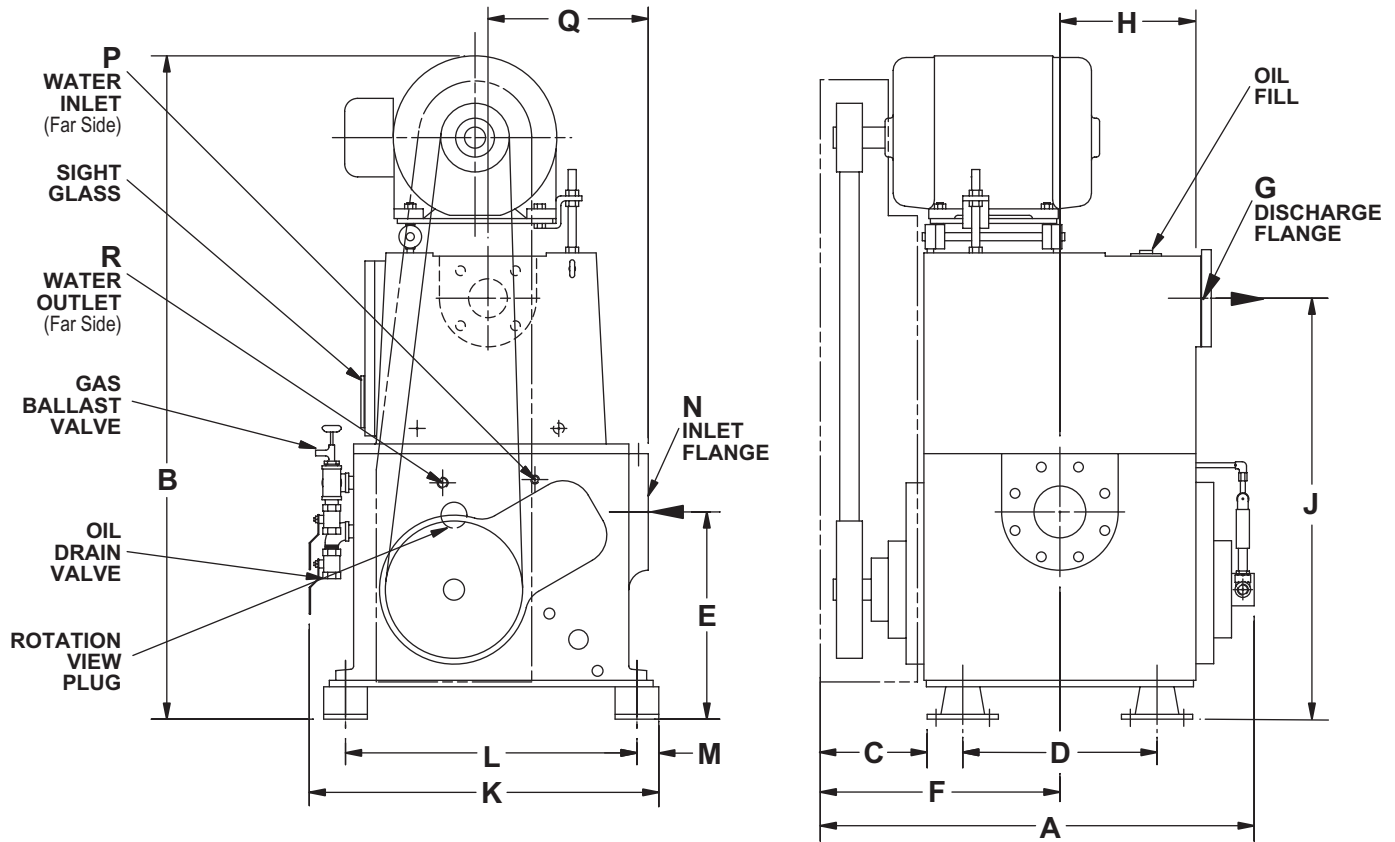

in. / mm	A	B	C	D	E	F	G DISCHARGE	H	J	K	L	M	N INLET	P	Q	R
KT-150C	26 660	43 1092	6.53 166	11.75 298	12.63 321	14.5 368	2" ANSI	7.25 184	28.2 716	22.75 578	19.13 486	1.19 30	3" ANSI	3/8 outlet	9.38 238	1/4 inlet
KT-300D	33.5 851	51.25 1302	8.25 210	15 381	16 406	18.5 470	3" ANSI	10.88 276	32.5 826	27 686	22.5 572	1.69 43	4" ANSI	3/8	12.38 314	1/2
KT-500D	37.25 946	63.13 1604	10.38 264	17 432	21.5 546	21.25 540	4" ANSI	11.75 298	41 1041	32.32 821	28 711	1.38 35	6" ANSI	3/8	15.38 391	1/2
KT-850D	48.5 1232	69.69 1770	12 305	24.75 629	24.25 616	25.75 654	5" ANSI	15.5 394	46 1168	38.06 967	33 838	1.38 29	8" ANSI	3/8	18.25 464	1/2

Your Local Tuthill Vacuum Blower Systems Sales Professional:



Western Washington: 253-740-0530  
 Eastern Washington: 509-949-3368  
 Idaho & Montana: 208-360-3833  
 Oregon: 503-708-9609  
[info@nwflowtech.com](mailto:info@nwflowtech.com)



Tuthill Vacuum & Blower Systems  
 4840 West Kearney Street  
 Springfield, Missouri USA 65803-8702  
 o 417.865.8715 800.825.6937 f 417.865.2950  
[tuthillvacuumblower.com](http://tuthillvacuumblower.com)

