

TITAN

Heavy Duty
AODD PUMPS
Houston, Texas

ONE TOUGH PUMP!



1"



1½" - 2"



3"

ISO
9001:2008
REGISTERED

Engineered for High Performance...



QUALITY • AVAILABILITY • PRICE

• AIR-OPERATED • DOUBLE DIAPHRAGM • PUMPS •

Titan Manufacturing has highly trained engineers and professional staff to provide:

- Customer Service
- Application Engineering
- Training
- Industry Knowledge
- Parts Availability
- Project Management

 *Feel free to call Titan engineering department for technical questions or application assistance.*

APPLICATIONS:

- Mining
- Construction
- Waste Water
- Aromatic Solvents
- Oil / Lube Transfer
- Bulk Unloading
- Material Transfer
- Sump Pumping
- Slurry Transfer
- Bilge Pumping
- Dry Powder Transfer
- Other Applications

ELASTOMERS:

- Neoprene
- Buna
- EPDM
- Viton
- PTFE
- TPES

Available in:

Four Sizes: 1", 1½", 2" & 3"

Call: (713) 283.7700 Fax (713) 283.7600

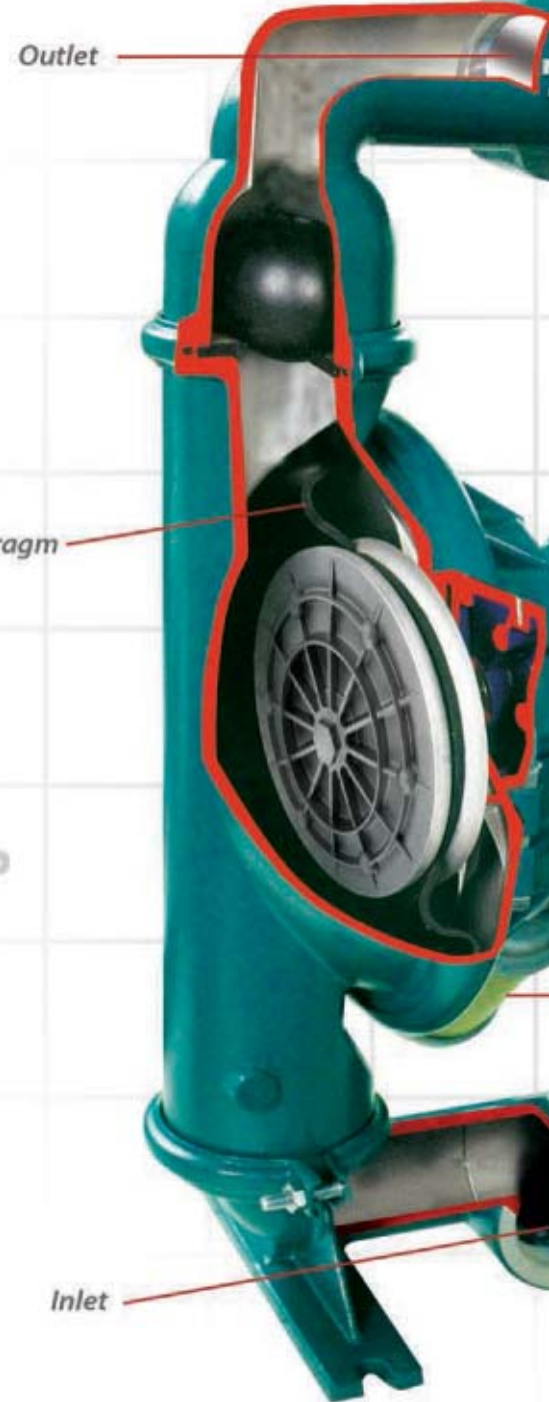

AODD PUMP

Solvents

Oils

Polymers

to perform... Built to last!

Parts 100% interchangeable with WILDEN®

Titan

AODD PUMPS



Air Supply

Muffler



High Viscosity

Low Viscosity

Paints

Experience the power of..... **Titan!**

T-25



1"

Specifications:

Air Inlet	6 mm	(1/4")
Inlet	25 mm	(1")
Outlet	19 mm	(3/4")
Suction Lift	5.18 m Dry	(17')
	9.45 m Wet	(31')
Max. Flow Rate	132 lpm	(35 gpm)
Max. Size Solids	3.2 mm	(1/8")
Height	279 mm	(11.0")
Width	267 mm	(10.5")
Depth	185 mm	(7.3")
Est. Ship Weight	Aluminum	12 kg (26 lbs)

Dimensional data:

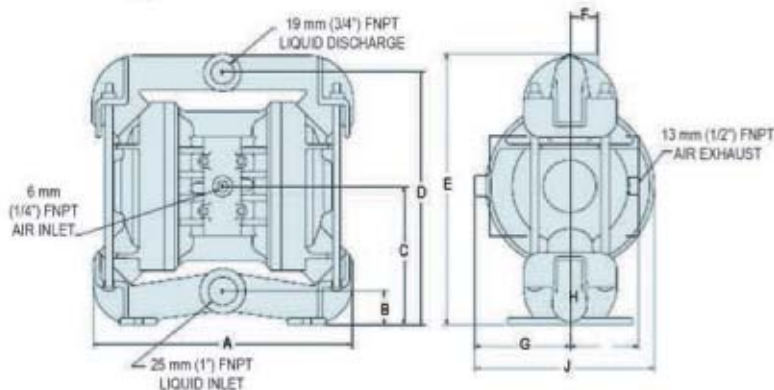
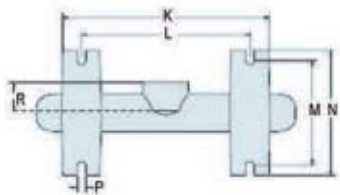

Caution: Do not exceed 8.6 bar (125 psig) air supply pressure.

Note: Teflon Diaphragms; reduce flow by 25%

CHART FOR RUBBER FITTED

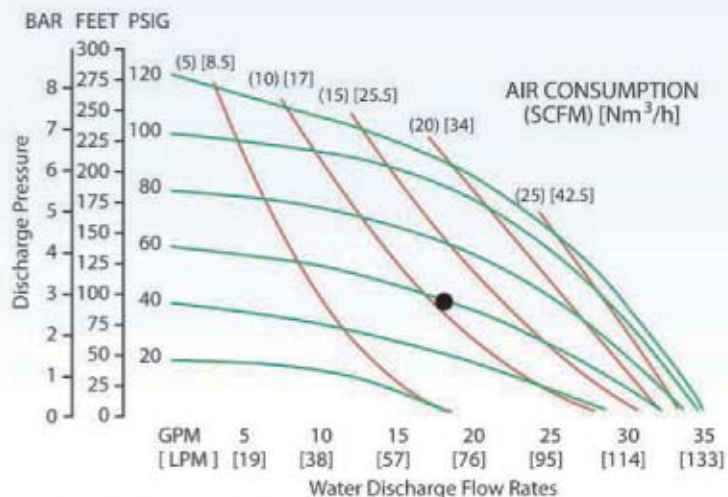

H₂O flow rates listed

For best performance, run pump at "center of curve".

DIMENSIONS

ITEM	METRIC (mm)	STANDARD (inch)
A	267	10.5
B	36	1.4
C	137	5.4
D	254	10.0
E	279	11.0
F	28	1.1
G	97	3.8
H	76	3.0
J	185	7.3
K	211	8.3
L	173	6.8
M	107	4.2
N	127	5.0
P	8	0.3
R	33	1.3

BSPT Threads available

CHART FOR TEFLON FITTED

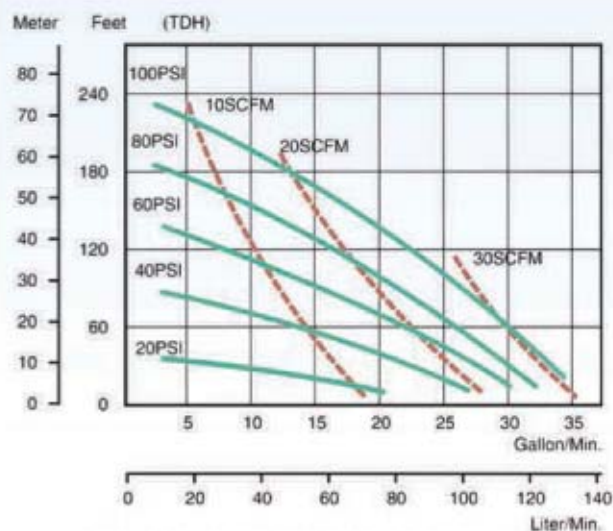

* Data based on 1-ft flooded suction; ambient water.

CHART FOR RUBBER FITTED



T-40

1 1/2"

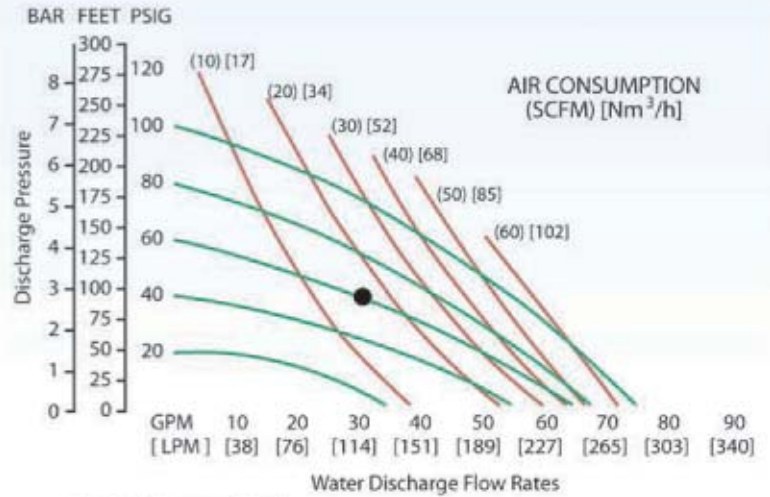

H₂O flow rates listed

For best performance, run pump at "center of curve".

Specifications:

Air Inlet	13 mm	(1/2")
Inlet	38 mm	(1-1/2")
Outlet	32 mm	(1-1/4")
Suction Lift	5.49 m Dry	(18')
	8.53 m Wet	(28')
Max. Flow Rate	288 lpm	(76 gpm)
Max. Size Solids	4.8 mm	(3/16")
Height	442 mm	(17.4")
Width	391 mm	(15.4")
Depth	285 mm	(11.2")
Est. Ship Weight	Aluminum	17 kg (38 lbs)

Dimensional data:

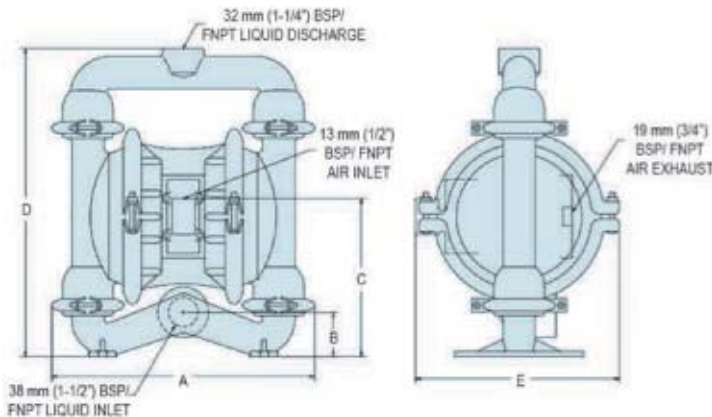
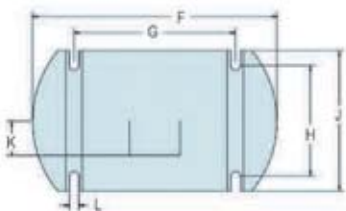

DIMENSIONS

ITEM	METRIC (mm)	STANDARD (inch)
A	391	15.4
B	63	2.5
C	219	8.6
D	442	17.4
E	285	11.2
F	338	13.3
G	224	8.8
H	152	6.0
J	193	7.6
K	67	2.6
L	11	0.4

BSP threads available.

CHART FOR TEFLON FITTED

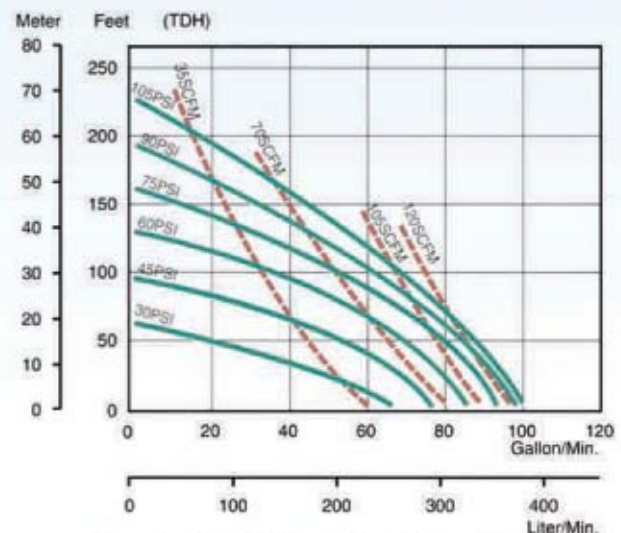

* Data based on 1-ft flooded suction; ambient water.

Caution: Do not exceed 8.6 bar (125 psig) air supply pressure.

Note: Teflon Diaphragms: reduce flow by 25%

Titan.....Excellence in Quality!



T-50

Specifications:

Air Inlet	19 mm	(3/4")
Inlet	51 mm	(2")
Outlet	51 mm	(2")
Suction	Lift 6.4 m Dry	(21')
	9.5 m Wet	(31')
Max. Flow Rate	617 lpm	(163 gpm)
Max. Size Solids	6.4 mm	(1/4")
Height	668 mm	(26.3")
Width	404 mm	(15.9")
Depth	343 mm	(13.5")
Est. Ship Weight	Aluminum	33 kg (72 lbs)

Dimensional data:

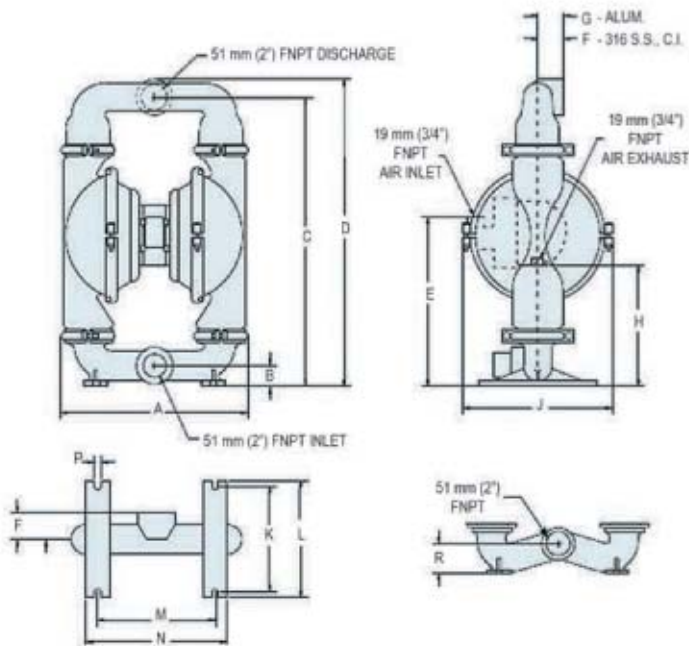
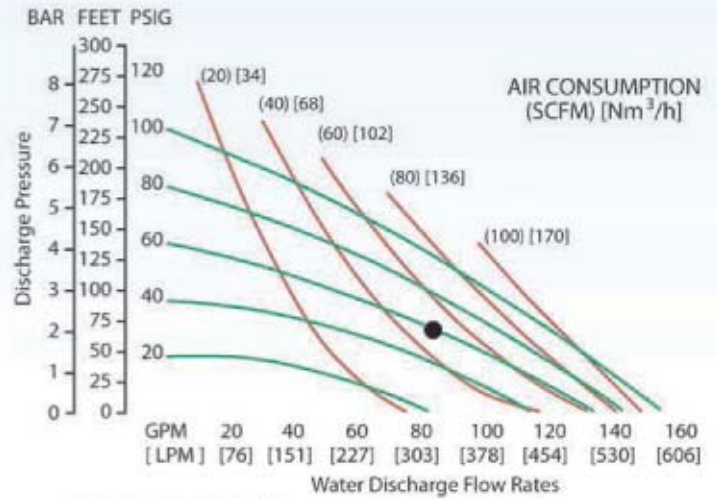

CHART FOR RUBBER FITTED



H2O flow rates listed

For best performance, run pump at "center of curve".

DIMENSIONS

ITEM	METRIC (mm)	STANDARD (inch)
A	404	15.9
B	48	1.9
C	630	24.8
D	668	26.3
E	361	14.2
F	58	2.3
G	61	2.4
H	272	10.7
J	343	13.5
K	229	9.0
L	254	10.0
M	257	10.1
N	312	12.3
P	15	0.6
R	64	2.5

BSP threads available.

CHART FOR TEFLON FITTED

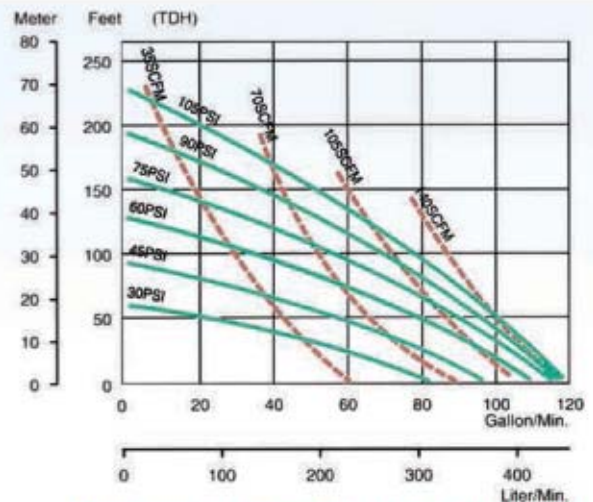

Caution: Do not exceed 8.6 bar (125 psig) air supply pressure.

Note: Teflon Diaphragms: reduce flow by 25%

* Data based on 1-ft flooded suction; ambient water.



T-80

Specifications:

Air Inlet	19 mm	(3/4")
Inlet	76 mm	(3")
Outlet	76 mm	(3")
Suction Lift	5.5 m Dry	(18')
	9.45 m Wet	(31')
Max. Flow Rate	878 lpm	(232 gpm)
Max. Size Solids	10 mm	(3/8")
Height	810 mm	(31.9")
Width	432 mm	(17.0")
Depth	279 mm	(11.0")
Est. Ship Weight	Aluminum	53 kg (116 lbs)

Dimensional data:

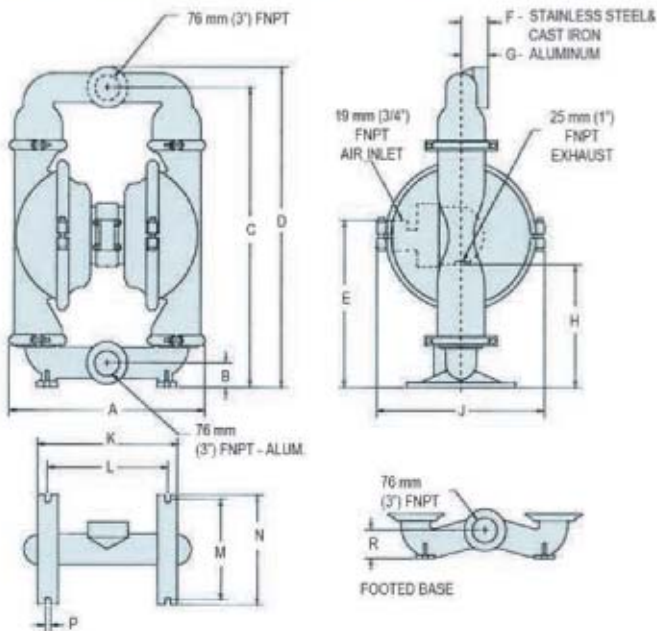

Caution: Do not exceed 8.6 bar (125 psig) air supply pressure.

Note: Teflon Diaphragms: reduce flow by 25%

Need assistance?....Call: (713) 283.7700

CHART FOR RUBBER FITTED

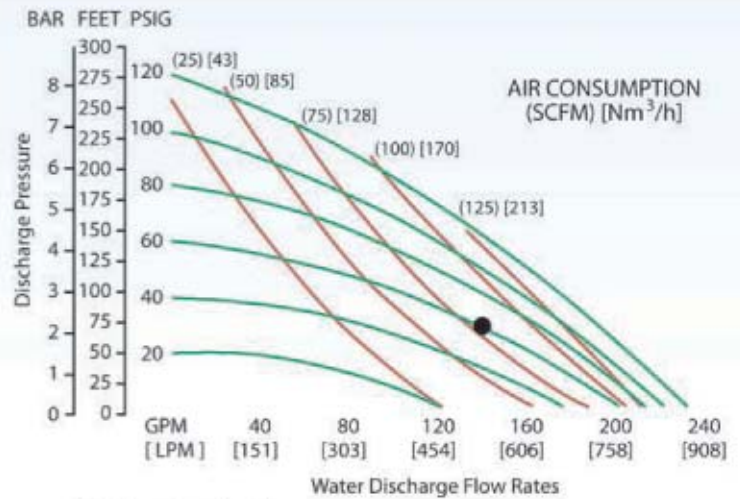

H₂O flow rates listed

For best performance, run pump at "center of curve".

DIMENSIONS

ITEM	METRIC (mm)	STANDARD (inch)
A	505	19.9
B	58	2.3
C	762	30.0
D	823	32.4
E	419	16.5
F	71	2.8
G	69	2.7
H	312	12.3
J	427	16.8
K	361	14.2
L	305	12.0
M	259	10.2
N	282	11.1
P	15	0.6
R	71	2.8

CHART FOR TEFLON FITTED

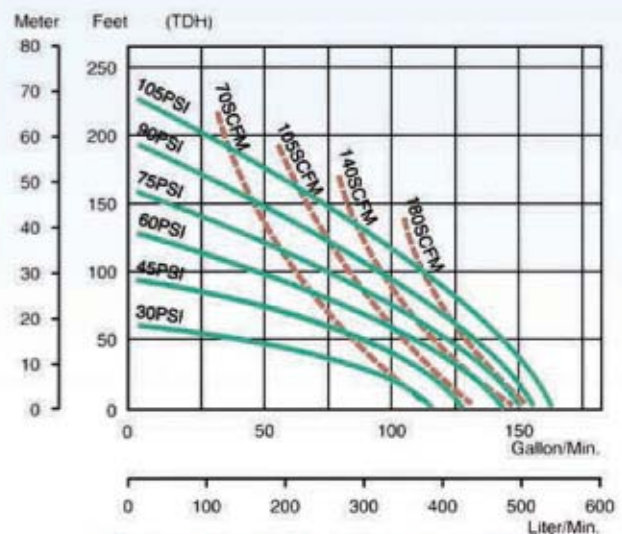

* Data based on 1-ft flooded suction; ambient water.

Titan T-25 & T-40

PARTS LIST

Item	Description		T-25		T-40	
			Rubber Fitted	PTFE Fitted	Rubber Fitted	PTFE Fitted
1-A	Air Valve Assembly	1	D02-2000-07	D02-2000-07	D04-2000-07	D04-2000-07
1-B	Air Valve Screen				D04-2500-07	D04-2500-07
2	Air Valve End Cap w/out Guide (Bottom)	1	D02-2331-23	D02-2331-23	D04-2300-23	D04-2300-23
3	Air Valve End Cap w/ Guide (Top)	1	D02-2301-23	D02-2301-23	D04-2330-23	D04-2330-23
4	Air Valve Snap Ring	2	D02-2650-03	D02-2650-03	D04-2650-03	D04-2650-03
5	Air Valve Cap O-ring	2	D02-3200-52-200	D02-3200-52-200	D04-2390-52	D04-2390-52
6	Air Valve Gasket	1	D02-2600-52	D02-2600-52	D04-2600-52	D04-2600-52
7	Center Section	1	D02-3151-20-225	D02-3151-20-225	D04-3150-20-225	D04-3150-20-225
8	Muffler Plate	1	D02-3180-20	D02-3180-20	D04-3180-20	D04-3180-20
9	Muffler Plate Gasket	1	D02-3500-52-500	D02-3500-52-500	D04-3500-52	D04-3500-52
10	Air Valve Cap Screw 1/4" - 20 x 2"	4	D02-6000-08	D02-6000-08	D04-6000-08	D04-6000-08
	Hex Head Nut 1/4" - 20 (Not Shown)	4	D02-6400-08	D02-6400-08	D04-6400-08	D04-6400-08
11	Center Block TRACKER™ Seal	4	D02-3210-77-225	D02-3210-77-225	D04-3210-77-225	D04-3210-77-225
12	Shaft / * Teflon	1	D02-3800-03-07	* D02-3820-09-07	D04-3800-03-07	* D04-3820-03-07
13	Shaft Stud	2	D02-6150-08	D02-6150-08	D04-6150-08	D04-6152-08
14	Disc Spring	2	D02-6802-08	D02-6802-08		
15	Inner Piston	2	D02-3750-01	D02-3750-01	D04-3700-08	D04-3752-01
16-A	Diaphragm - Neoprene / * Teflon	2	D02-1010-51	* D02-1010-55	D04-1010-51	* D04-1010-55
16-B	Backup Diaphragm		D02-1060-52		D04-1060-52	
17	Outer Piston	2	D02-4601-01	D02-4601-01	D04-4552-01	D04-4600-01
18	Liquid Chamber	2	D02-5000-01	D02-5000-01	D04-5000-01	D04-5000-01
19	Discharge Manifold	1	D02-5020-01	D02-5020-01	D04-5020-01	D04-5020-01
20	Inlet Manifold	1	D02-5080-01	D02-5080-01	D04-5080-01	D04-5080-01
21	Manifold Bolt 3/6" - 16 x 8-1/2"	4	D02-6080-08	D02-6080-08		
22	Muffler	1	D02-3510-99	D02-3510-99	D04-3510-99	D04-3510-99
23	Valve Ball - Neoprene / * Teflon	4	D02-1080-51	* D02-1080-55	D04-1080-51	* D04-1080-55
24	Valve Seat - Aluminum	4	D02-1120-01	D02-1120-01	D04-1120-51	D04-1121-01
25	Valve Seat O-ring - Neoprene / * Teflon	4	D02-1200-51	* D02-1200-55	D04-1200-52	* D04-1200-55
26	Manifold Bolt Washer 3/8"	4	D02-6720-08	D02-6720-08		
27	Manifold Bolt Nut 3/8" - 16	4	D02-6430-08	D02-6430-08		
28	Clamp Band (Large)	2			D04-7330-08	D04-7330-08
29	Clamp Band (Small)	4			D04-7100-08	D04-7100-08
30	Large Clamp Bolts 5/16" - 18 x 2-1/4"	4			D04-6070-08	D04-6070-08
31	Large Hex Nut 5/16" - 18	4			D04-6420-08	D04-6420-08
32	Small Clamp Band Bolts 1/4" - 20 x 1-3/4"	8			D04-6050-08	D04-6050-08
33	Small Hex Nut 1/4" x 20	8			D04-6400-08	D04-6400-08

Installation Applications

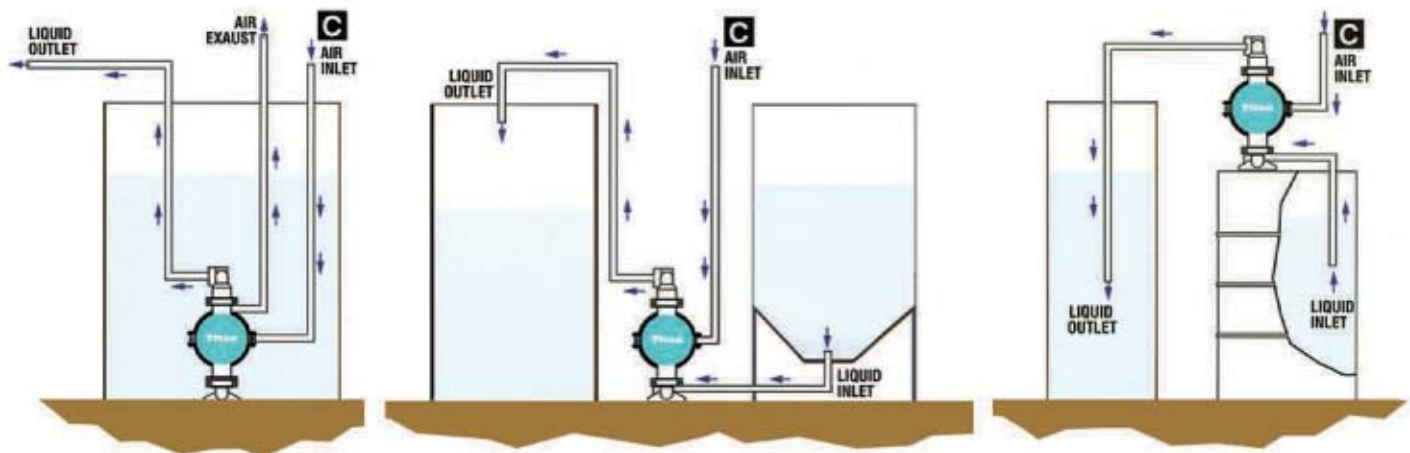

Pumping by Design!

C = Compressor Line

Isometric Drawing

T-25

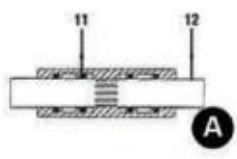
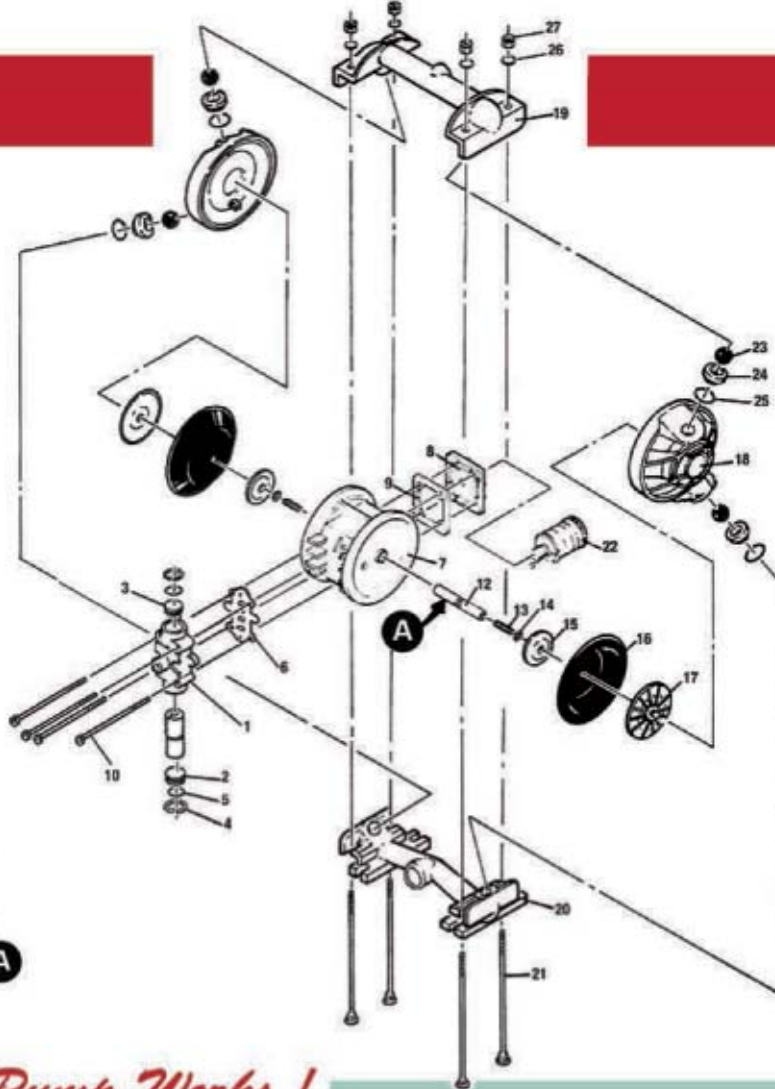

Isometric Drawing

T-40

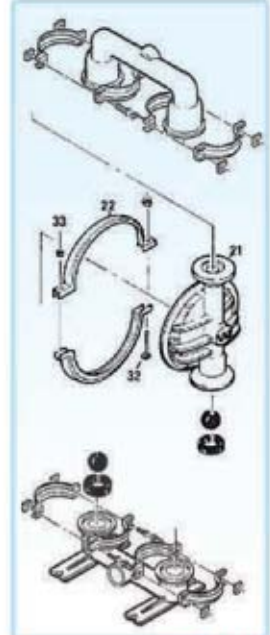

T-40

How the Pump Works!

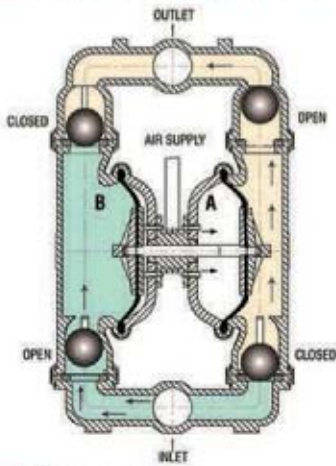

FIGURE 1 (LEFT STROKE)

The air valve directs pressurized air to the back side of diaphragm A. The compressed air is applied directly to the liquid column separated by elastomeric diaphragms. The diaphragm acts as a separation membrane between the compressed air and liquid, balancing the load and removing mechanical stress from the diaphragm. The compressed air moves the diaphragm away from the center block of the pump. The opposite diaphragm is pulled in by the shaft connected to the pressurized diaphragm. Diaphragm B is on its suction stroke; air behind the diaphragm has been forced out to the atmosphere through the exhaust port of the pump. The movement of diaphragm B toward the center block of the pump creates a vacuum within chamber B. Atmospheric pressure forces fluid into the inlet manifold forcing the inlet valve ball off its seat. Liquid is free to move past the inlet valve ball and fill the liquid chamber (see shaded area).

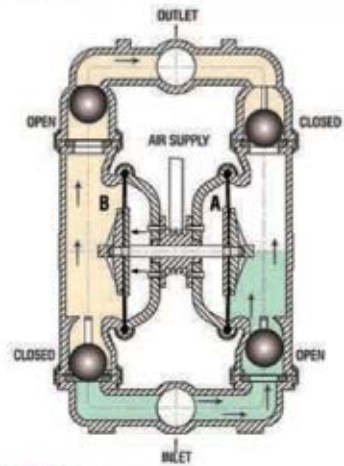

FIGURE 2 (MID STROKE)

When the pressurized diaphragm, diaphragm A, reaches the limit of its discharge stroke, the air valve redirects pressurized air to the back side of diaphragm B. The pressurized air forces diaphragm B away from the center block while pulling diaphragm A to the center block. Diaphragm B is now on its discharge stroke. Diaphragm B forces the inlet valve ball onto its seat due to the hydraulic forces developed in the liquid chamber and manifold of the pump. These same hydraulic forces lift the discharge valve ball off its seat, while the opposite discharge valve ball is forced onto its seat, forcing fluid to flow through the pump discharge. The movement of diaphragm A toward the center block of the pump creates a vacuum within liquid chamber A. Atmospheric pressure forces fluid into the inlet manifold of the pump. The inlet valve ball is forced off its seat allowing the fluid being pumped to fill the liquid chamber.

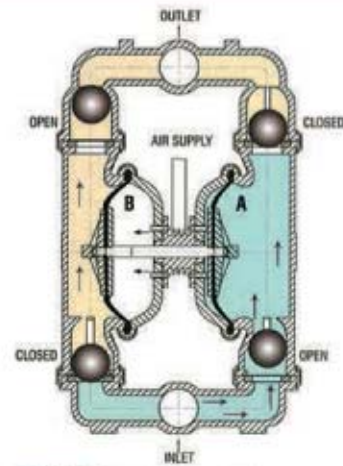

FIGURE 3 (RIGHT STROKE)

At completion of the stroke, the air valve again redirects air to the back side of diaphragm A, which starts diaphragm B on its exhaust stroke. As the pump reaches its original starting point, each diaphragm has gone through one exhaust and one discharge stroke. This constitutes one complete pumping cycle. The pump may take several cycles to completely prime depending on the conditions of the application.

The Titan diaphragm pump is an air-operated, positive displacement, self-priming pump. These drawings show the flow pattern through the pump upon its initial stroke.

It is assumed the pump has no fluid in it prior to its initial stroke.

Titan T-50 & T-80

PARTS LIST

Item	Description	T-50		T-80	
		Rubber Fitted	PTFE Fitted	Rubber Fitted	PTFE Fitted
1	Air Valve Assembly	1	D08-2000-07	D08-2000-07	D15-2000-07
2	Air Valve Screen	1	D08-2500-07	D08-2500-07	D15-2500-07
3	Air Valve End Cap w/ Guide (Top)	1	D08-2300-23	D08-2300-23	D15-2300-23
4	Air Valve End Cap w/out Guide (Bottom)	1	D08-2330-23	D08-2330-23	D15-2330-23
5	Air Valve Snap Ring	2	D08-2650-03	D08-2650-03	D15-2650-03
6	Air Valve Cap O-ring	2	D08-2390-52	D08-2390-52	D15-2390-52
10	Air Valve Gasket	1	D08-2600-52	D08-2600-52	D15-2600-52
11	Air Valve Screw 5/16" - 18 x 2 1/4"	4	D08-6000-08	D08-6000-08	D15-6000-08
12	Center Block	1	D08-3100-01-225	D08-3100-01-225	D15-3100-01-225
13	Center Block TRACKER™ Seal	7	D08-3210-77-225	D08-3210-77-225	D15-3210-77-225
14	Block Gasket	2	D08-3520-52	D08-3520-52	D15-3520-52
15-A	Shaft *Teflon	1	D08-3800-09-07	* D08-3820-03-07	D15-3800-09-07
15-B	Shaft Studd 1/2" - 20 x 1 - 7/8"			D08-6152-08	
16	Outer Piston	2	D08-4550-01	D08-4600-01	D15-4550-01
17	Inner Piston	2	D08-3700-01	D08-3750-01	D15-3700-01
18	Inner Piston Back-up Washer	2			D15-6850-08
19	Piston Assembly - Bolt 2 3/8" - 16 x 1 1/2"	12			D15-6130-08
	Washer, Flat (Not Shown)	12			D15-6720-08
20	Air Chamber	2	D08-3650-01	D08-3650-01	D15-3650-01
21	Air Chamber Screw 3/8" - 16 x 4"	4	D08-6200-08	D08-6200-08	D15-6200-08
22	Air Chamber Cone Nut 3/8" - 16	4	D08-6550-08	D08-6550-08	D15-6550-08
23	Liquid Chamber	2	D08-5000-01	D08-5000-01	D15-5000-01
24	Discharge Manifold	1	D08-5020-01	D08-5020-01	D15-5020-01
26	Inlet Manifold	1	D08-5080-01	D08-5080-01	D15-5080-01
30-A	Diaphragm - Neoprene / *Teflon	2	D08-1010-51	* D08-1010-55	* D15-1010-55
30-B	Backup Diaphragm Teflon	2		D08-1060-52	D15-1060-52
31	Valve Ball - Neoprene / *Teflon	4	D08-1080-51	* D08-1080-55	* D15-1080-55
32	Valve Seat - Neoprene / *Teflon	4	D08-1120-51	* D08-1121-01	* D15-1120-01
33	Large Clamp Band Assembly	2	D08-7300-08	D08-7300-08	D15-7300-08
34	Large Carriage Bolt 1/2" - 13 x 3 1/2"	4	D08-6120-08	D08-6120-08	D15-6120-08
35	Large Hex Nut 1/2" - 13	4	D08-6420-08	D08-6420-08	D15-6420-08
36	Small Clamp Band Assembly	4	D08-7100-08	D08-7100-08	D15-7100-08
37	Small Carriage Bolt 3/8" - 16 x 2"	8	D08-6050-08	D08-6050-08	D15-6050-08
38	Small Hex Nut 3/8" - 16	8	D08-6450-08	D08-6400-08	D15-6450-08
39	PTFE Valve Seat O-Ring	4		D08-1200-55	D15-1200-55
	Muffler (Not Shown)	1	D08-3510-99	D08-3510-99	D15-3510-99
	Washer, Flat (Not Shown)	8		D08-6720-07-70	
	Check Ball (Not Shown)	1	D08-1450-51	D08-1450-51	D15-1450-51
	Check Body (Not Shown)	1	D08-3550-01	D08-3550-01	D15-3550-01
	Pipe Nipple (Not Shown)	1	D08-7420-08	D08-7420-08	D15-7420-08

Suggested Installation

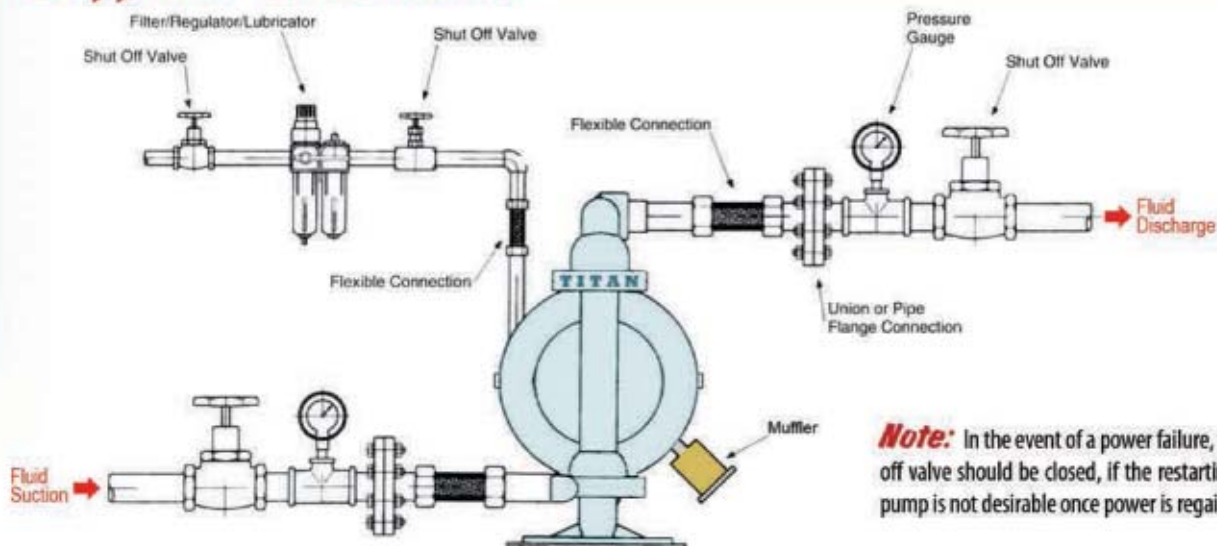

Note: In the event of a power failure, the shut-off valve should be closed, if the restarting of the pump is not desirable once power is regained.

Isometric Drawing T-50 & T-80

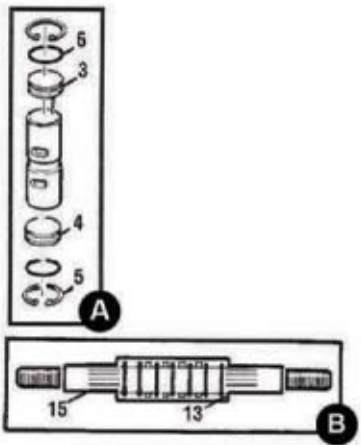
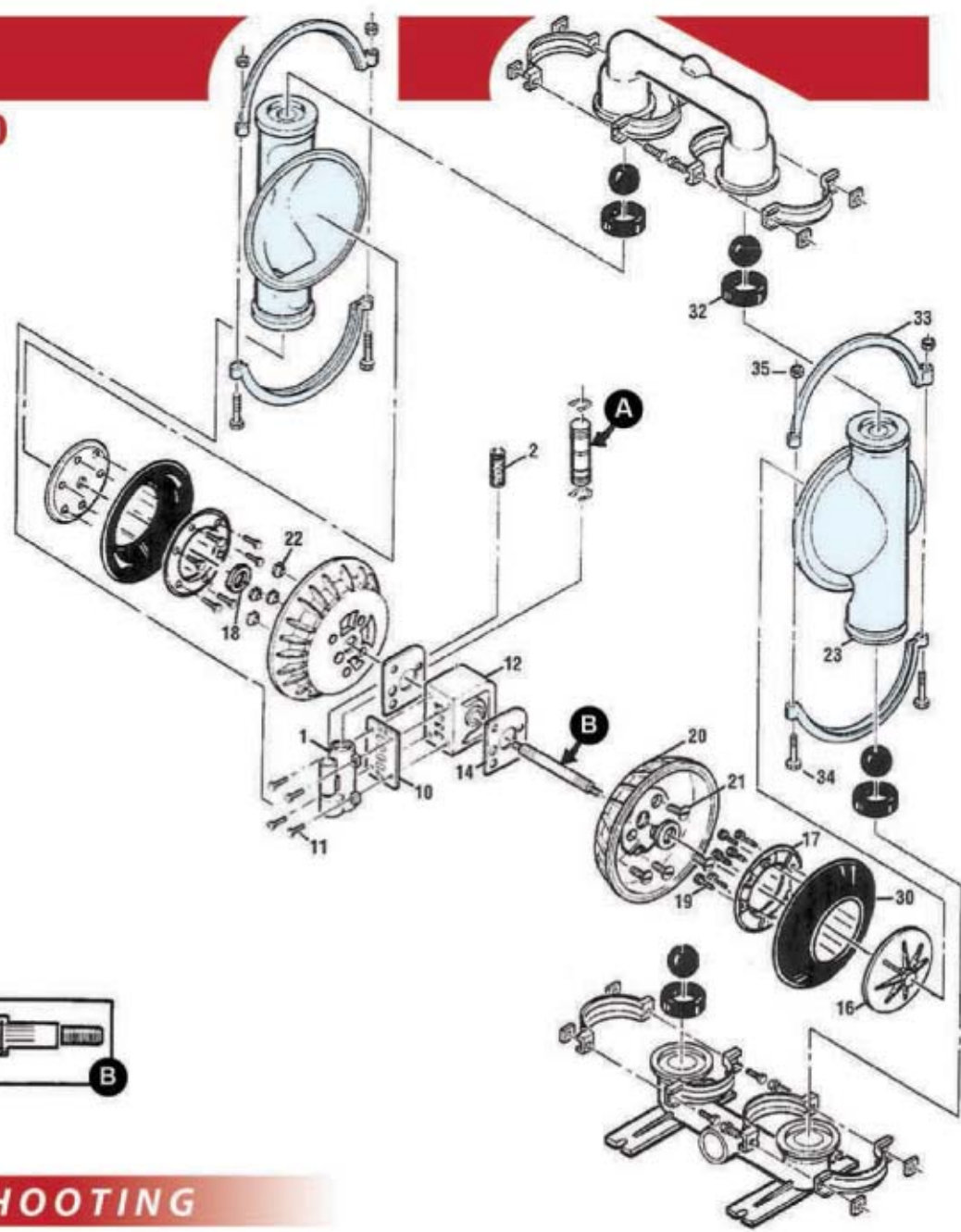

TROUBLESHOOTING

- **Pump will not run or runs slowly.**
 1. Check air inlet screen and air filter for debris.
 2. Check for sticking air valve, flush air valve in solvent.
 3. Check for worn out air valve. If piston face in air valve is shiny instead of dull, air valve is worn beyond working tolerances and must be replaced.
 4. Check center block rings. If worn excessively, they will not seal and air will simply flow through pump and out air exhaust.
 5. Check type of lubricant being used. ISO 15-5 wt. recommended.
- **Pump runs but little or no product flows.**
 1. Check for pump cavitation; slow pump speed down to match thickness of material being pumped.
 2. Check for sticking ball valves. If material being pumped is not compatible with pump elastomers, swelling may occur.
 3. Make sure all suction connections are air tight.
- **Pump air valve freezes.**
Check for excessive moisture in compressed air.

Air bubbles in pump discharge.
 1. Check for ruptured diaphragm.
 2. Check for tightness for clamp bands, especially at intake manifold.
- **Product comes out air exhaust.**
 1. Check for diaphragm rupture.
 2. Check tightness of piston plates to shaft.
- **Pump rattles.**
Create false discharge head or suction lift.

When quality counts...count on **Titan!**



Mining



ANSI

Chemical / Process



Trash



Asphalt

Rotary Gear

*World Class Pumps
... for Less!*



Custom skid packages



Drilling



Butterfly Valves

Hammer Drains



Assembly

DISCLAIMER:

The information and data contained in this catalog are accurate to the best of our knowledge, but are intended for general information only. Applications suggested for the materials are described only to help readers make their own evaluation, and are neither guarantees nor to be construed as expressed or implied warranties of suitability for these or other applications. Titan Manufacturing, Inc. makes no warranty either expressed or implied beyond that stipulated in Titan Manufacturing, Inc. Standard Terms and Conditions of Sale.

In Stock!



Warehouse



Titan Manufacturing Facility: 45,000 sq. ft.