

LR1A - LANTERN SINGLE STAGE LIQUID RING VACUUM PUMPS





EDWARDS THE PARTNER OF CHOICE

Edwards is a world leader in the design, technology and manufacture of vacuum pumps for industrial applications with over 100 years' history.

We believe in delivering results that bring value to our customers by using our breadth of industry experience to identify and apply solutions. Using the most innovative and up-to-date modelling techniques, we can optimise the pumping configuration for customers to provide a system design giving the maximum performance in the most reliable and cost-effective way.

EDWARDS LR1A LANTERN SERIES OF SINGLE STAGE LIQUID RING VACUUM PUMPS

The LR1A single-stage liquid ring pumps are tolerant of particulates and operate with minimal maintenance and noise. Designed for operation across your vacuum range, right down to 33 mbara, these pumps include an enhanced bearing design, enabling reduced internal clearances for improved efficiency. The curved blade impeller, with reinforcing rings, delivers improved ruggedness, reducing noise and vibrations.

The LR1A range can be customised in three basic configurations: Once-through, Partial and Total Recirculation mode, making them ideal for continuous operation in chemical, petrochemical, power, and general industry applications.



A CHOICE OF CONFIGURATIONS

With more than 100 years of experience and thousands of global installations, we can help you choose the best configuration that is right for your application. All our liquid ring pumps are offered in a variety of configurations to suit your needs. They can be installed in a single or multi pump setup as required. The LR1A Lantern series is offered in pre-engineered plug and play modules, suitable for operation in the Once-through, Partial Recirculation or Total Recovery mode. The easy to install accessories from our standard range help you complete the installation for your application.



ENGINEERED TO ORDER

We can help you meet your process and project specific requirements with our rich experience of successful installations in various applications. For more complex requirements, our project team is here to develop a unique engineered system tailored to your needs. Our liquid ring pumps form the backbone of multi-stage systems in your choice of materials as per the specifications you need. Using our years of experience to design, engineer, and assemble LR1A pumps to order, the possibilities are endless.



KEY FEATURES

- Low operating noise and vibration
- Operate across entire vacuum range
- Various material of construction
- Low maintenance
- No metal-to-metal contact
- Rugged, robust construction
- Various seals are available upon request
- Variable port design for high pressure running
- Low temperature operation
- Tolerance to high back pressure
- Manufactured to ISO 9001

LR1A200



MATERIALS OF CONSTRUCTION

Component	CI/SS	SS 304	SS 316L
End casings	CI/HT200	SS 304	SS 316L
Manifold*	CS/Q235	SS 304	SS 316L
Port plates	CI/HT200	SS 304	SS 316L
Center body	CS/Q235	SS 304	SS 316L
Impeller		SS 304	SS 316L
Shaft	2Cr13	2205	
Bearing housing	CI/HT200		
Valve plate	PTFE		
Shaft seals			
Single mechanical seal	Faces	SiC vs carbon	
	Elastomers	FKM	
	Metal parts	SS 316	
Gland packing*	PTFE fibre with graphite impregnation		
Double mechanical seal*	For details, contact Edwards		

*Optional configuration

TECHNICAL SPECIFICATIONS

Model	Capacity m ³ /h	Speed rpm	Flow rate m ³ /h	Motor rating kW	Ultimate vacuum mbara	Back pressure mbara	Weight kg	Noise dB(A)	Vibration mm/s
LR1A200 (50 Hz)	168	1450	2.6	5.5	33	1300*	54	85	2.8
LR1A200 (60 Hz)	202	1750	3.2	7.5	33	1300*	54	85	2.8

* For higher back pressure, please consult Edwards.

PERFORMANCE CURVES

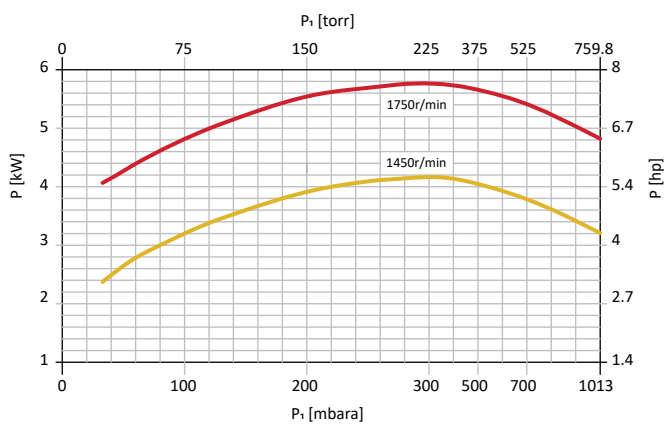
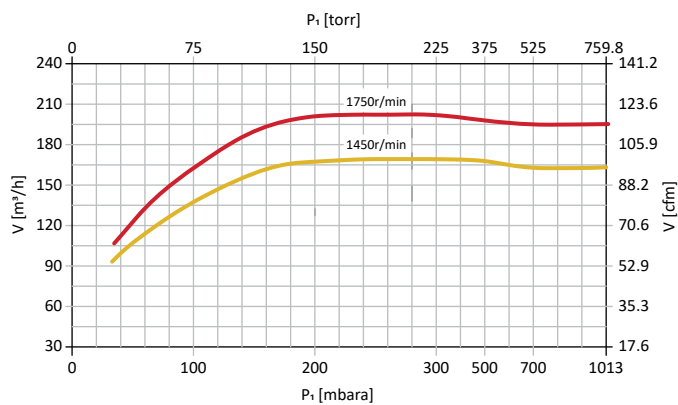

The performances shown are based on operating conditions with saturated air at 20 °C, service water at 15 °C, and exhaust pressure at the standard atmospheric pressure of 1,013.25 mbar. The performance tolerance is ±10%.

DIMENSIONS

All dimensions are in mm.

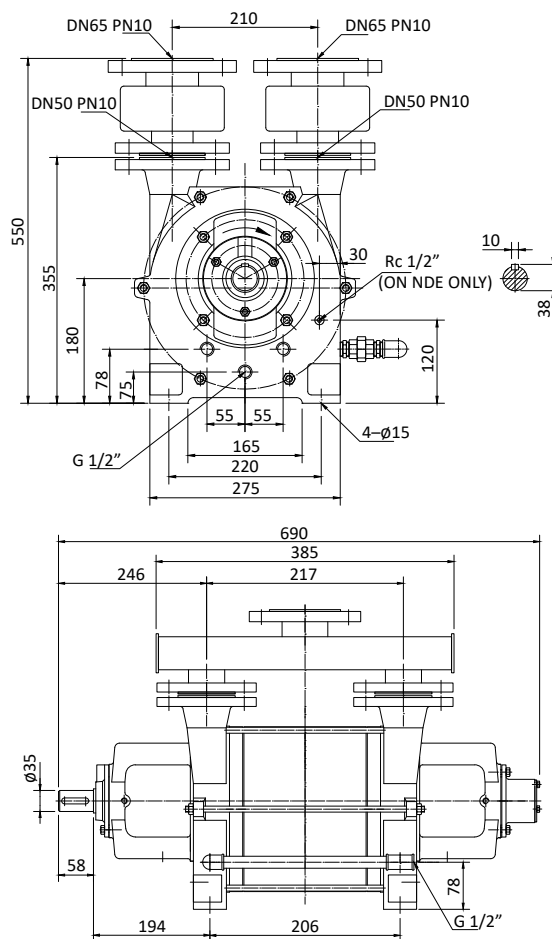

LR1A300



MATERIALS OF CONSTRUCTION

Component	CI/SS	SS 304	SS 316L
End casings	CI/HT200	SS 304	SS 316L
Manifold*	CS/Q235	SS 304	SS 316L
Port plates	CI/HT200	SS 304	SS 316L
Center body	CS/Q235	SS 304	SS 316L
Impeller		SS 304	SS 316L
Shaft	2Cr13	2205	
Bearing housing	CI/HT200		
Valve plate	PTFE		
Shaft seals			
Single mechanical seal	Faces	SiC vs carbon	
	Elastomers	FKM	
	Metal parts	SS 316	
Gland packing*	PTFE fibre with graphite impregnation		
Double mechanical seal*	For details, contact Edwards		

*Optional configuration

TECHNICAL SPECIFICATIONS

Model	Capacity m ³ /h	Speed rpm	Flow rate m ³ /h	Motor rating kW	Ultimate vacuum mbara	Back pressure mbara	Weight kg	Noise dB(A)	Vibration mm/s
LR1A300 (50 Hz)	146	1450	2.6	7.5	33	1300*	137	85	2.8
LR1A300 (60 Hz)	290	1750	3	11	33	1300*	137	85	2.8

* For higher back pressure, please consult Edwards.

PERFORMANCE CURVES

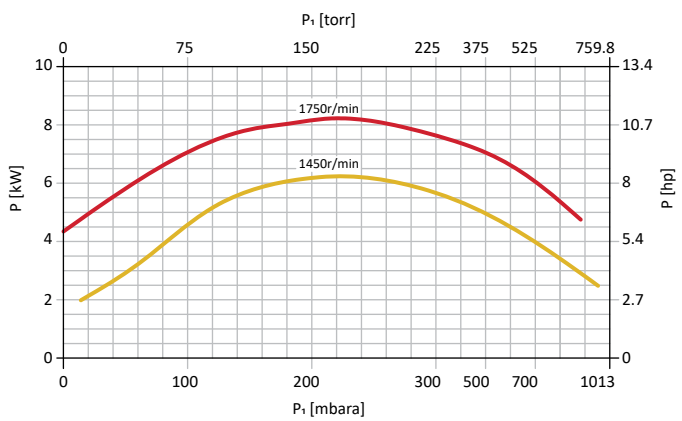
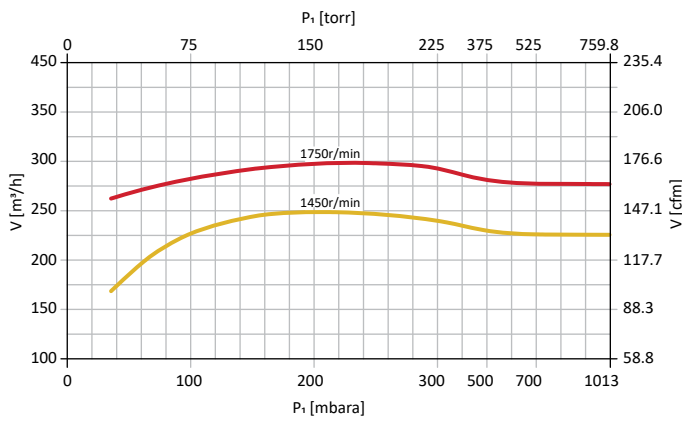

The performances shown are based on operating conditions with saturated air at 20 °C, service water at 15 °C, and exhaust pressure at the standard atmospheric pressure of 1,013.25 mbar. The performance tolerance is ±10%.

DIMENSIONS

All dimensions are in mm.

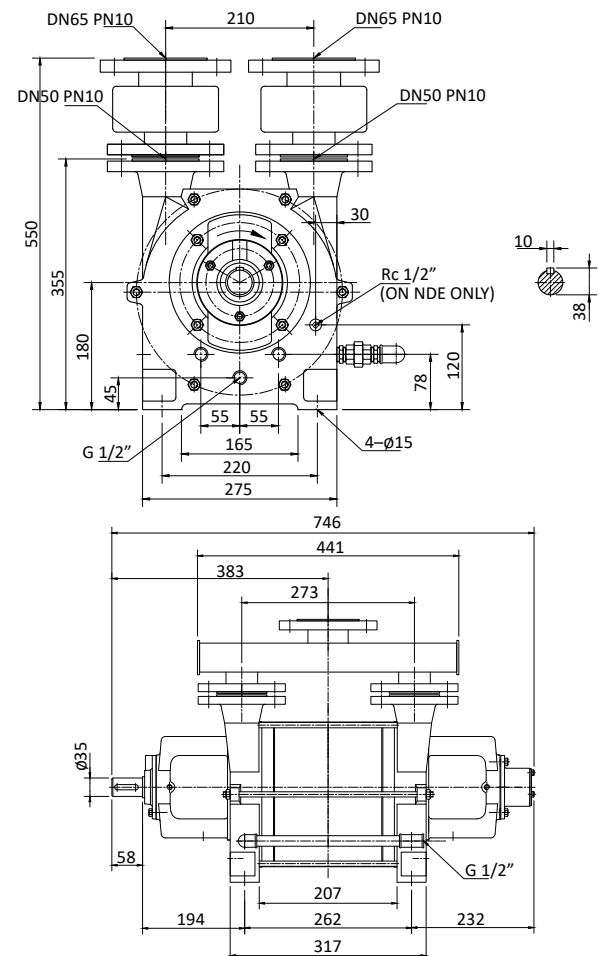

LR1A400



MATERIALS OF CONSTRUCTION

Component	CI/SS	SS 304	SS 316L
End casings	CI/HT200	SS 304	SS 316L
Manifold*	CS/Q235	SS 304	SS 316L
Port plates	CI/HT200	SS 304	SS 316L
Center body	CS/Q235	SS 304	SS 316L
Impeller		SS 304	SS 316L
Shaft	2Cr13	2205	
Bearing housing	CI/HT200		
Valve plate	PTFE		
Shaft seals			
Single mechanical seal	Faces	SiC vs carbon	
	Elastomers	FKM	
	Metal parts	SS 316	
Gland packing*	PTFE fibre with graphite impregnation		
Double mechanical seal*	For details, contact Edwards		

*Optional configuration

TECHNICAL SPECIFICATIONS

Model	Capacity m ³ /h	Speed rpm	Flow rate m ³ /h	Motor rating kW	Ultimate vacuum mbara	Back pressure mbara	Weight kg	Noise dB(A)	Vibration mm/s
LR1A400 (50 Hz)	340	1450	2.8	11	33	1300*	152	85	2.8
LR1A400 (60 Hz)	412	1750	3.4	15	33	1300*	152	85	2.8

* For higher back pressure, please consult Edwards.

PERFORMANCE CURVES

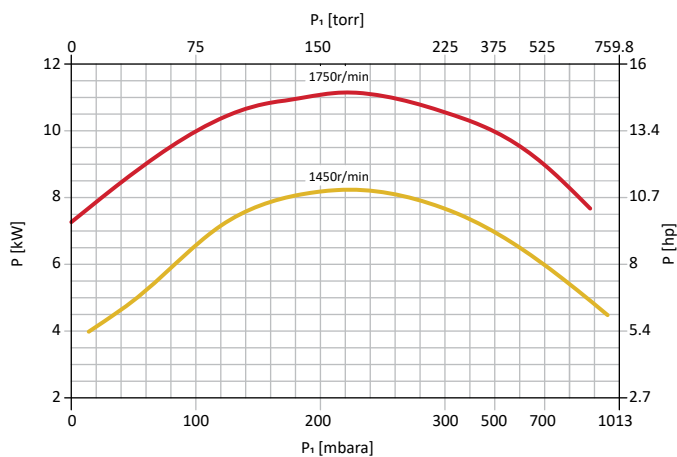
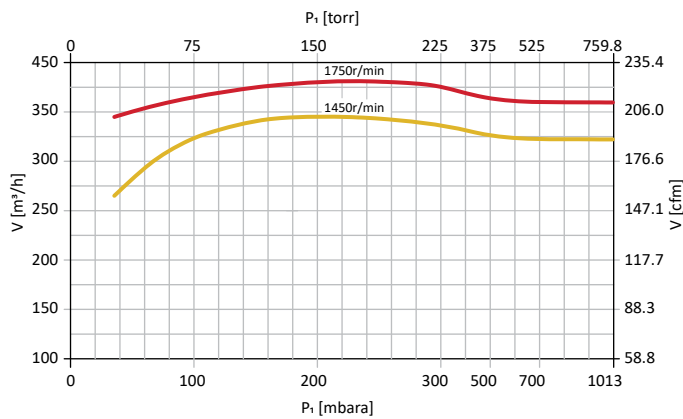

The performances shown are based on operating conditions with saturated air at 20 °C, service water at 15 °C, and exhaust pressure at the standard atmospheric pressure of 1,013.25 mbar. The performance tolerance is ±10%.

DIMENSIONS

All dimensions are in mm.

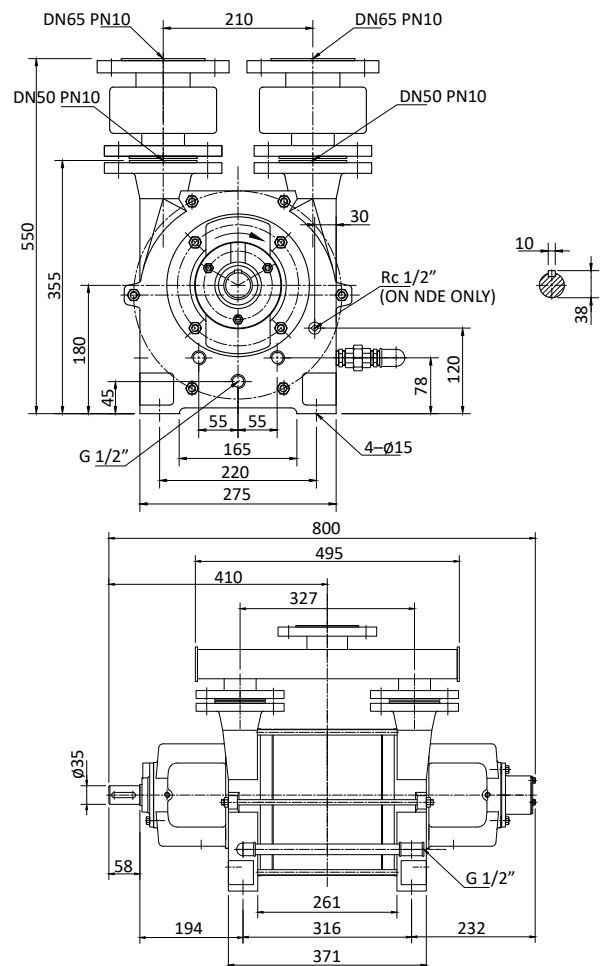

LR1A500



MATERIALS OF CONSTRUCTION

Component	CI	CI/SS	SS 304	SS 316L
End casings	CI/HT200		SS 304	SS 316L
Manifold*	CS/Q235		SS 304	SS 316L
Port plates	CI/HT200		SS 304	SS 316L
Centre body	CS/Q235		SS 304	SS 316L
Impeller	Pheroidal graphite CI/QT400		SS 304	SS 316L
Shaft		SS 2Cr13		2205
Bearing housing		CI/HT200		
Valve plate			PTFE	
Shaft seals				
Single mechanical seal	Faces	SiC vs carbon		
	Elastomers	FKM		
	Metal parts	SS 316		
Gland packing*	PTFE fibre with graphite impregnation			
Double mechanical seal*	For details, contact Edwards			

*Optional configuration

TECHNICAL SPECIFICATIONS

Model	Capacity m ³ /h	Speed rpm	Flow rate m ³ /h	Motor rating kW	Ultimate vacuum mbara	Back pressure mbara	Weight kg	Noise dB(A)	Vibration mm/s
LR1A500 (50 Hz)	450	1450	3.4	15	33	1300*	175	85	2.8
LR1A500 (60 Hz)	535	1750	4.2	22	33	1300*	175	85	2.8

* For higher back pressure, please consult Edwards.

PERFORMANCE CURVES

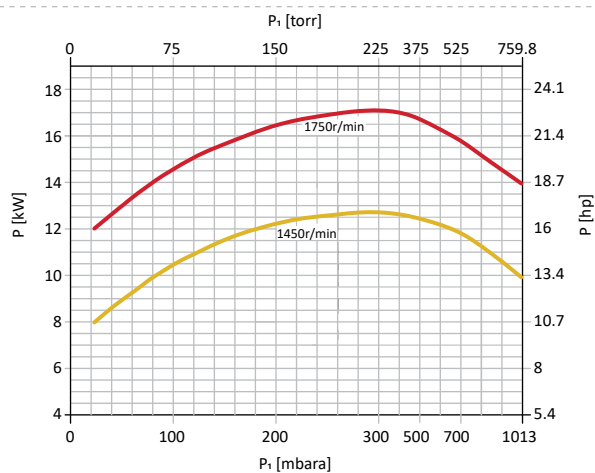
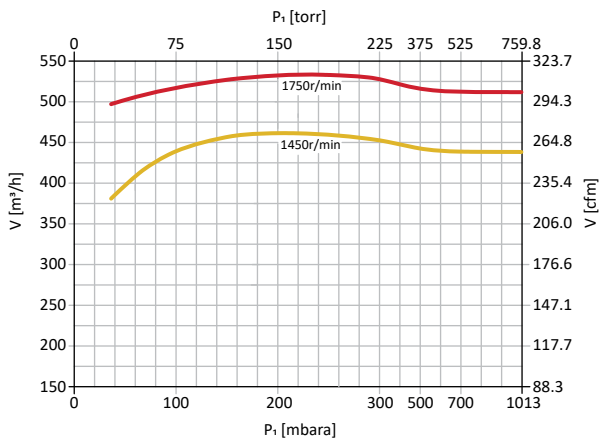

The performances shown are based on operating conditions with saturated air at 20 °C, service water at 15 °C, and exhaust pressure at the standard atmospheric pressure of 1,013.25 mbar. The performance tolerance is ±10%.

DIMENSIONS

All dimensions are in mm.

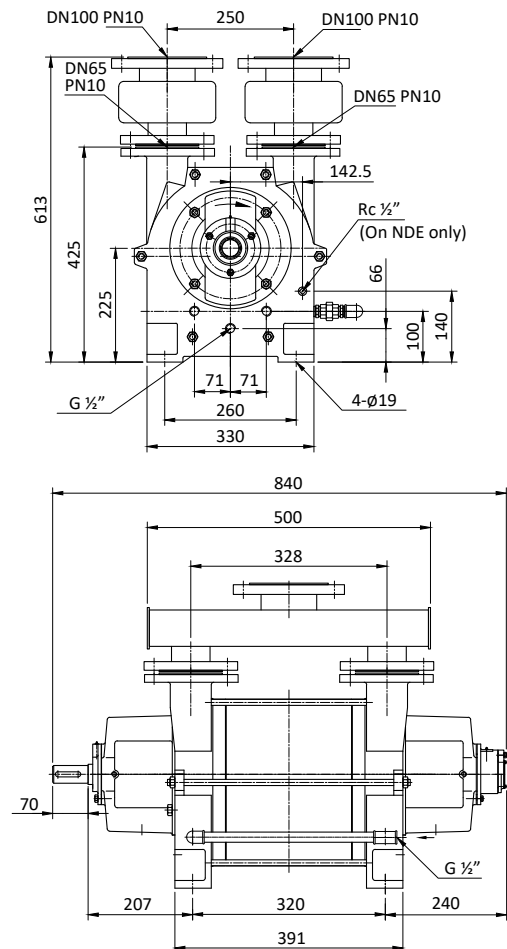

LR1A700



MATERIALS OF CONSTRUCTION

Component	CI	CI/SS	SS 304	SS 316L
End casings	CI/HT200		SS 304	SS 316L
Manifold*	CS/Q235		SS 304	SS 316L
Port plates	CI/HT200		SS 304	SS 316L
Centre body	CS/Q235		SS 304	SS 316L
Impeller	Pheroidal graphite CI/QT400		SS 304	SS 316L
Shaft		SS 2Cr13		2205
Bearing housing		CI/HT200		
Valve plate			PTFE	
Shaft seals				
Single mechanical seal	Faces		SiC vs carbon	
	Elastomers		FKM	
	Metal parts		SS 316	
Gland packing*			PTFE fibre with graphite impregnation	
Double mechanical seal*			For details, contact Edwards	

*Optional configuration

TECHNICAL SPECIFICATIONS

Model	Capacity m ³ /h	Speed rpm	Flow rate m ³ /h	Motor rating kW	Ultimate vacuum mbara	Back pressure mbara	Weight kg	Noise dB(A)	Vibration mm/s
LR1A700 (50 Hz)	600	1450	3.8	18.5	33	1300*	208	85	2.8
LR1A700 (60 Hz)	700	1750	4.6	30	33	1300*	208	85	2.8

* For higher back pressure, please consult Edwards.

PERFORMANCE CURVES

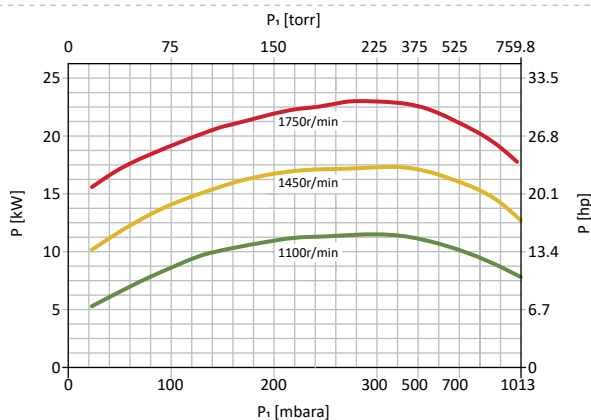
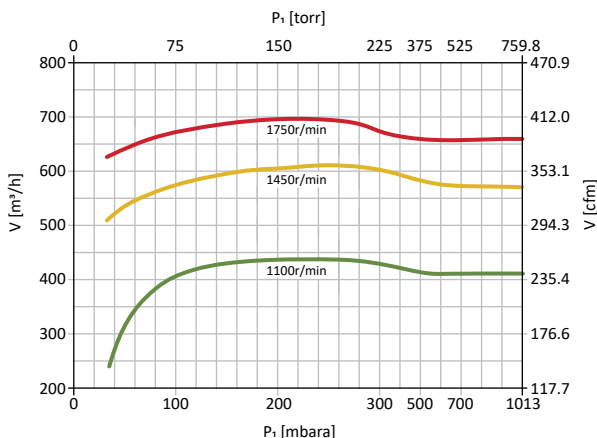

The performances shown are based on operating conditions with saturated air at 20 °C, service water at 15 °C, and exhaust pressure at the standard atmospheric pressure of 1,013.25 mbar. The performance tolerance is ±10%.

DIMENSIONS

All dimensions are in mm.

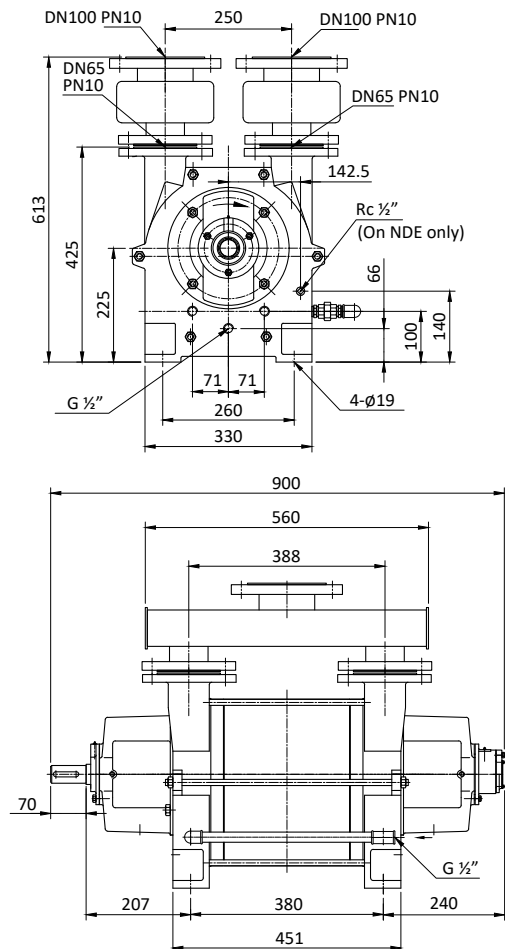

LR1A800

MATERIALS OF CONSTRUCTION

Component	CI	CI/SS	SS 304	SS 316L
End casings	CI/HT200		SS 304	SS 316L
Manifold*	CS/Q235		SS 304	SS 316L
Port plates	CI/HT200		SS 304	SS 316L
Centre body	CS/Q235		SS 304	SS 316L
Impeller	Pheroidal graphite CI/QT400		SS 304	SS 316L
Shaft		SS 2Cr13		2205
Sleeve		SS 304		SS 316L
O-ring			FKM	
Bearing housing		CI/HT200		
Valve plate			PTFE	
Shaft seals				
Single mechanical seal	Faces	SiC vs carbon		
	Elastomers	FKM		
	Metal parts	SS 316		
Gland packing*	PTFE fibre with graphite impregnation			
Double mechanical seal*	For details, contact Edwards			

*Optional configuration



TECHNICAL SPECIFICATIONS

Model	Capacity m ³ /h	Speed rpm	Flow rate m ³ /h	Motor rating kW	Ultimate vacuum mbara	Back pressure mbara	Weight kg	Noise dB(A)	Vibration mm/s
LR1A800 (50 Hz)	750	980	4.2	22	33	1300*	362	85	2.8
LR1A800 (60 Hz)	888	1170	5	30	33	1300*	362	85	2.8

* For higher back pressure, please consult Edwards.

PERFORMANCE CURVES

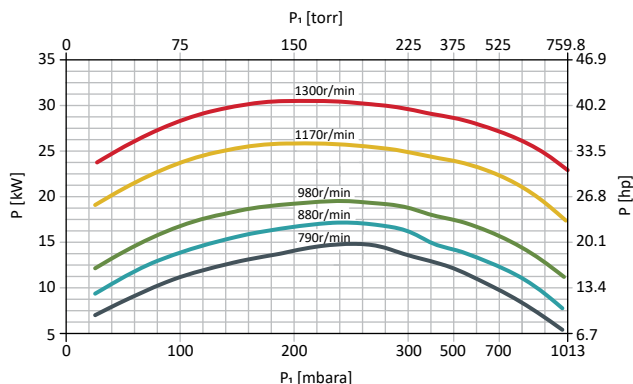
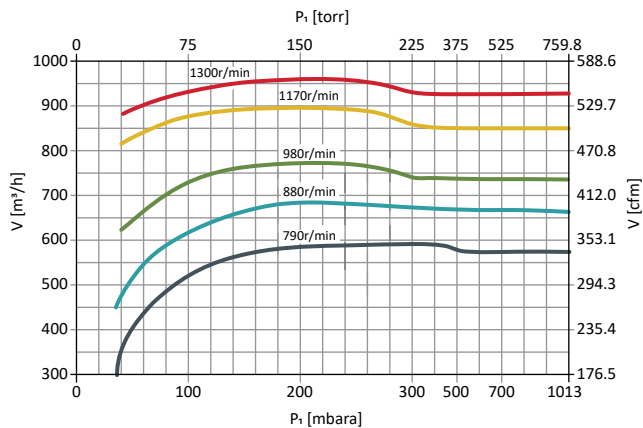

The performances shown are based on operating conditions with saturated air at 20 °C, service water at 15 °C, and exhaust pressure at the standard atmospheric pressure of 1,013.25 mbar. The performance tolerance is ±10%.

DIMENSIONS

All dimensions are in mm.

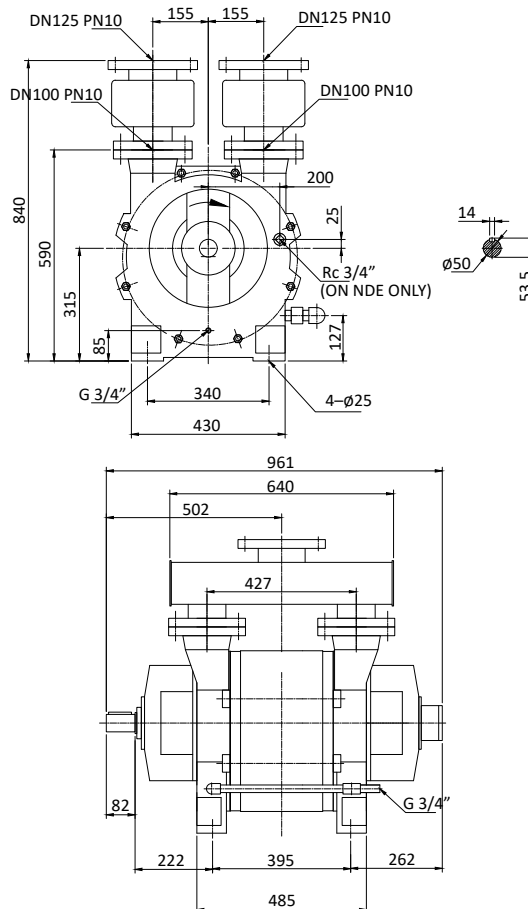

LR1A1200



MATERIALS OF CONSTRUCTION

Component	CI	CI/SS	SS 304	SS 316L
End casings	CI/HT200		SS 304	SS 316L
Manifold*	CS/Q235		SS 304	SS 316L
Port plates	CI/HT200		SS 304	SS 316L
Centre body	CS/Q235		SS 304	SS 316L
Impeller	Pheroidal graphite CI/QT400		SS 304	SS 316L
Shaft	CS/Q235		SS 2Cr13	
Sleeve	SS 304			SS 316L
O-ring	FKM			
Bearing housing	CI/HT200			
Valve plate	PTFE			
Shaft seals				
Single mechanical seal	Faces		SiC vs carbon	
	Elastomers		FKM	
	Metal parts		SS 316	
Gland packing*		PTFE fibre with graphite impregnation		
Double mechanical seal*		For details, contact Edwards		

*Optional configuration

TECHNICAL SPECIFICATIONS

Model	Capacity m ³ /h	Speed rpm	Flow rate m ³ /h	Motor rating kW	Ultimate vacuum mbara	Back pressure mbara	Weight kg	Noise dB(A)	Vibration mm/s
LR1A1200 (50 Hz)	1080	980	5.2	37	33	1300*	437	85	2.8
LR1A1200 (60 Hz)	1320	1170	6.2	45	33	1300*	437	85	2.8

* For higher back pressure, please consult Edwards.

PERFORMANCE CURVES

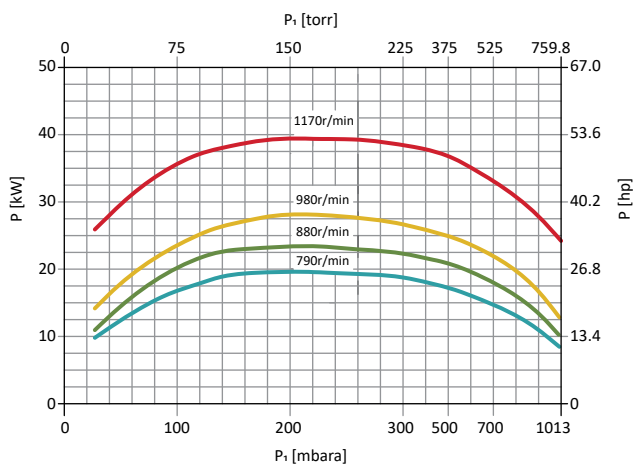
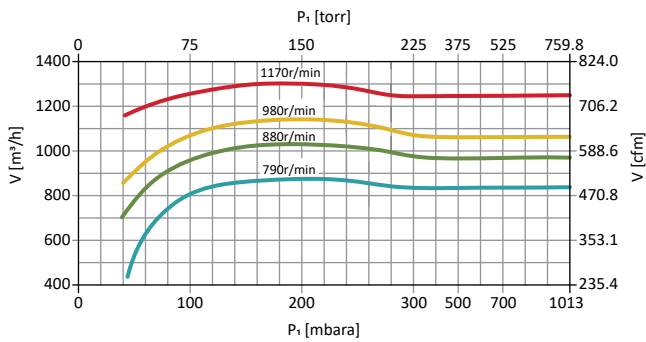

The performances shown are based on operating conditions with saturated air at 20 °C, service water at 15 °C, and exhaust pressure at the standard atmospheric pressure of 1,013.25 mbar. The performance tolerance is ±10%.

DIMENSIONS

All dimensions are in mm.

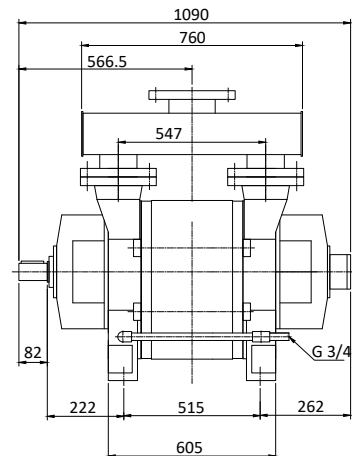
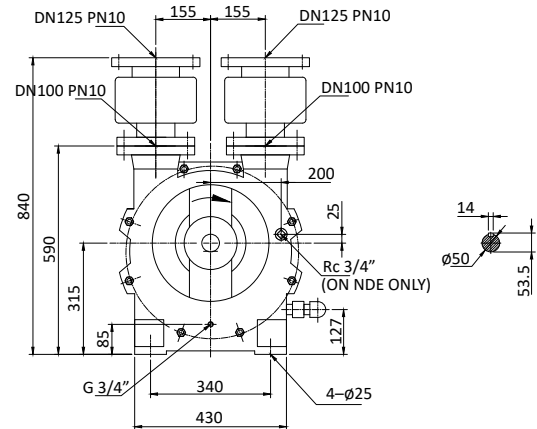

LR1A1300

MATERIALS OF CONSTRUCTION



Component	CI	CI/SS	SS 304	SS 316L
End casings	CI/HT200		SS 304	SS 316L
Manifold*	CS/Q235		SS 304	SS 316L
Port plates	CI/HT200		SS 304	SS 316L
Centre body	CS/Q235		SS 304	SS 316L
Impeller	Pheroidal graphite CI/QT400		SS 304	SS 316L
Shaft	CS/Q235		SS 2Cr13	
Sleeve	SS 304			SS 316L
O-ring	FKM			
Bearing housing	CI/HT200			
Valve plate	PTFE			
Shaft seals				
Single mechanical seal	Faces		SiC vs carbon	
	Elastomers		FKM	
	Metal parts		SS 316	
Gland packing*		PTFE fibre with graphite impregnation		
Double mechanical seal*		For details, contact Edwards		

*Optional configuration

TECHNICAL SPECIFICATIONS

Model	Capacity m ³ /h	Speed rpm	Flow rate m ³ /h	Motor rating kW	Ultimate vacuum mbara	Back pressure mbara	Weight kg	Noise dB(A)	Vibration mm/s
LR1A1300 (50 Hz)	1230	980	12	37	33	1300*	470	85	2.8
LR1A1300 (60 Hz)	1452	1170	14.4	55	33	1300*	470	85	2.8

* For higher back pressure, please consult Edwards.

PERFORMANCE CURVES

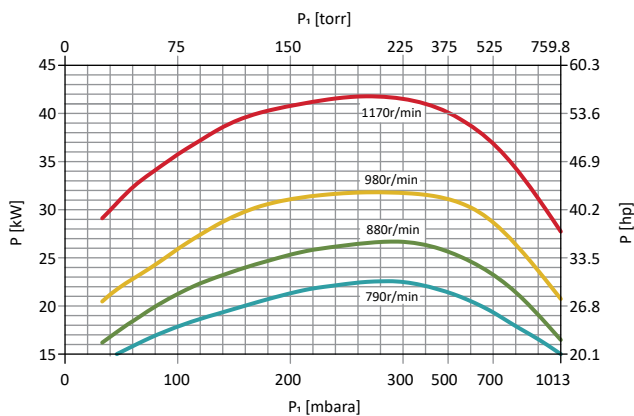
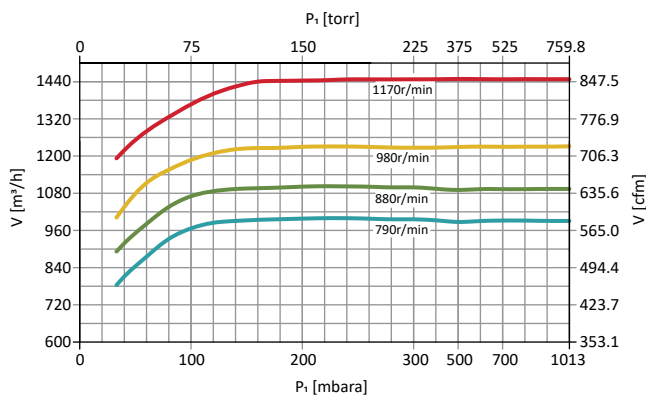

The performances shown are based on operating conditions with saturated air at 20 °C, service water at 15 °C, and exhaust pressure at the standard atmospheric pressure of 1,013.25 mbar. The performance tolerance is ±10%.

DIMENSIONS

All dimensions are in mm.

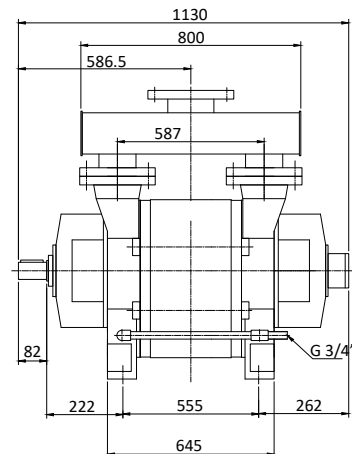
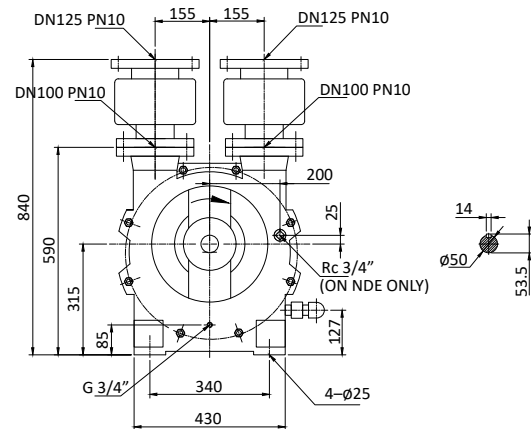

LR1A1600



MATERIALS OF CONSTRUCTION

Component	CI	CI/SS	SS 304	SS 316L
End casings	CI/HT200		SS 304	SS 316L
Manifold*	CS/Q235		SS 304	SS 316L
Port plates	CI/HT200		SS 304	SS 316L
Centre body	CS/Q235		SS 304	SS 316L
Impeller	Pheroidal graphite CI/QT400		SS 304	SS 316L
Shaft	CS/Q235		SS 2Cr13	
Sleeve	SS 304			SS 316L
O-ring	FKM			
Bearing housing	CI/HT200			
Valve plate	PTFE			
Shaft seals				
Single mechanical seal	Faces	SiC vs carbon		
	Elastomers	FKM		
	Metal parts	SS 316		
Gland packing*	PTFE fibre with graphite impregnation			
Double mechanical seal*	For details, contact Edwards			

*Optional configuration

TECHNICAL SPECIFICATIONS

Model	Capacity m ³ /h	Speed rpm	Flow rate m ³ /h	Motor rating kW	Ultimate vacuum mbara	Back pressure mbara	Weight kg	Noise dB(A)	Vibration mm/s
LR1A1600 (50 Hz)	1700	740	8.8	45	33	1300*	887	85	2.8
LR1A1600 (60 Hz)	2000	880	10.4	75	33	1300*	887	85	2.8

* For higher back pressure, please consult Edwards.

PERFORMANCE CURVES

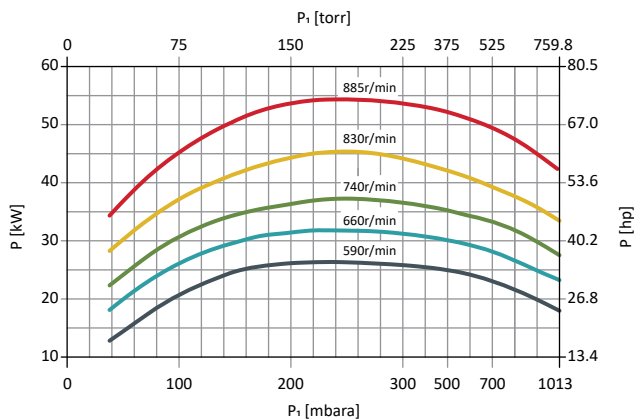
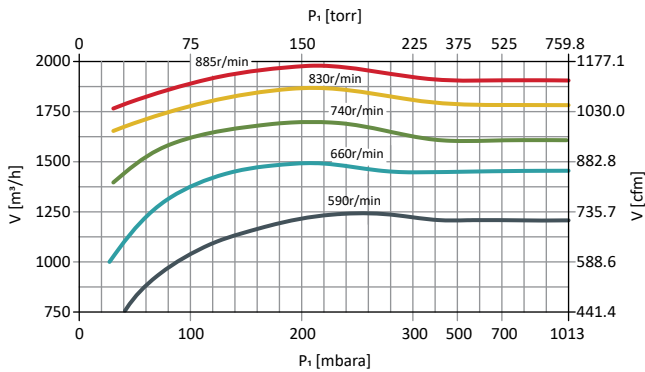

The performances shown are based on operating conditions with saturated air at 20 °C, service water at 15 °C, and exhaust pressure at the standard atmospheric pressure of 1,013.25 mbar. The performance tolerance is ±10%.

DIMENSIONS

All dimensions are in mm.

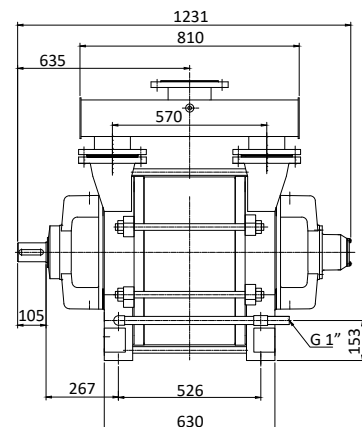
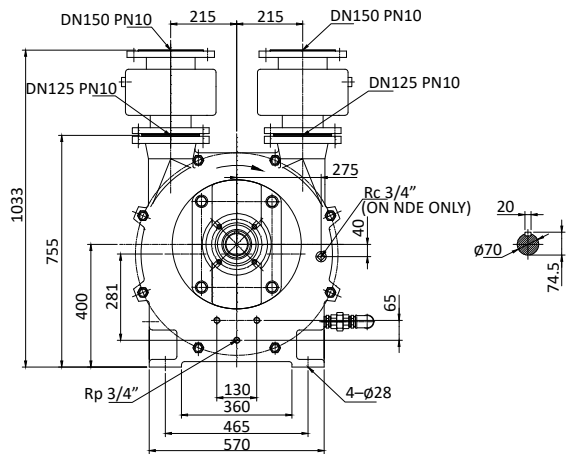

LR1A2500



TECHNICAL SPECIFICATIONS

Model	Capacity m ³ /h	Speed rpm	Flow rate m ³ /h	Motor rating kW	Ultimate vacuum mbara	Back pressure mbara	Weight kg	Noise dB(A)	Vibration mm/s
LR1A2500 (50 Hz)	2450	740	10.4	75	33	1300*	809	85	2.8
LR1A2500 (60 Hz)	2780	880	12.4	90	33	1300*	809	85	2.8

* For higher back pressure, please consult Edwards.

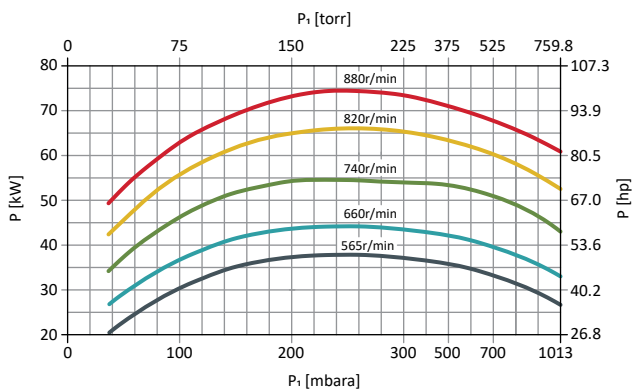
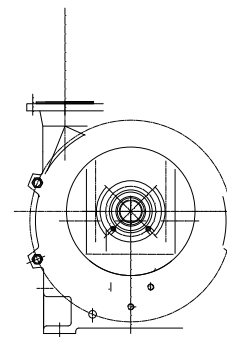
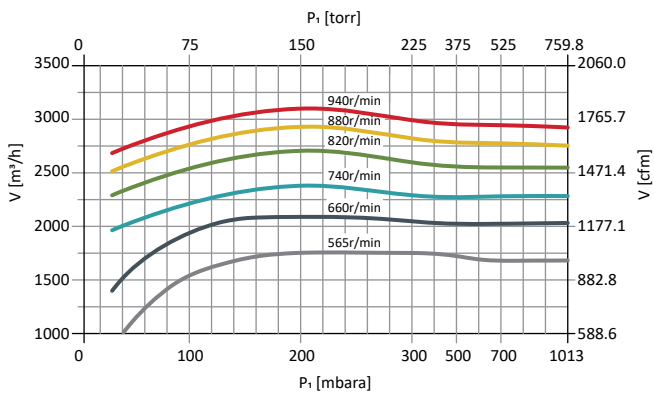

LR1A5000



MATERIALS OF CONSTRUCTION

Component	CI	CI/SS	SS 304	SS 316L
End casings	CI/HT200		SS 304	SS 316L
Manifold*	CS/Q235		SS 304	SS 316L
Port plates	CI/HT200		SS 304	SS 316L
Centre body	CS/Q235		SS 304	SS 316L
Impeller	Pheroidal graphite CI/QT400		SS 304	SS 316L
Shaft	CS/Q235		SS 2Cr13	
Sleeve		SS 304		SS 316L
O-ring		FKM		
Bearing housing		CI/HT200		
Valve plate		PTFE		
Shaft seals				
Single mechanical seal	Faces	SiC vs carbon		
	Elastomers	FKM		
	Metal parts	SS 316		
Gland packing*	PTFE fibre with graphite impregnation			
Double mechanical seal*	For details, contact Edwards			

*Optional configuration

TECHNICAL SPECIFICATIONS

Model	Capacity m ³ /h	Speed rpm	Flow rate m ³ /h	Motor rating kW	Ultimate vacuum mbara	Back pressure mbara	Weight kg	Noise dB(A)	Vibration mm/s
LR1A5000 (50/60 Hz)	4550	740	18.2	132	33	1300*	1735	85	2.8

* For higher back pressure, please consult Edwards.

PERFORMANCE CURVES

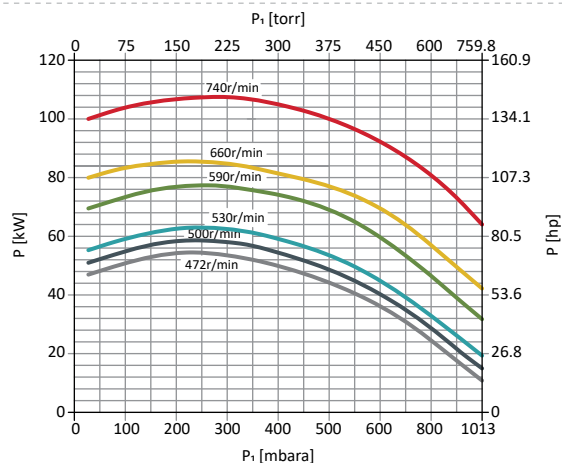
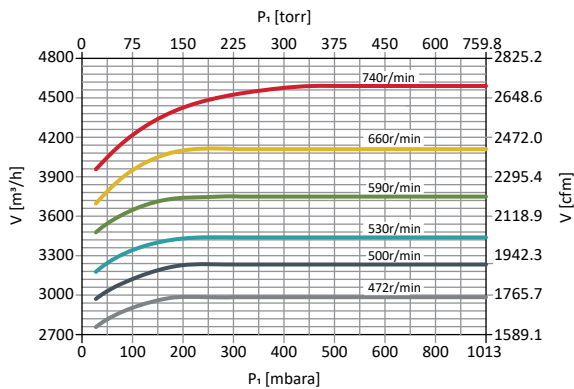

The performances shown are based on operating conditions with saturated air at 20 °C, service water at 15 °C, and exhaust pressure at the standard atmospheric pressure of 1,013.25 mbar. The performance tolerance is ±10%.

DIMENSIONS

All dimensions are in mm.

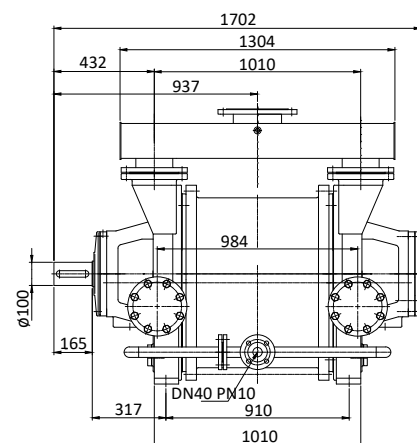
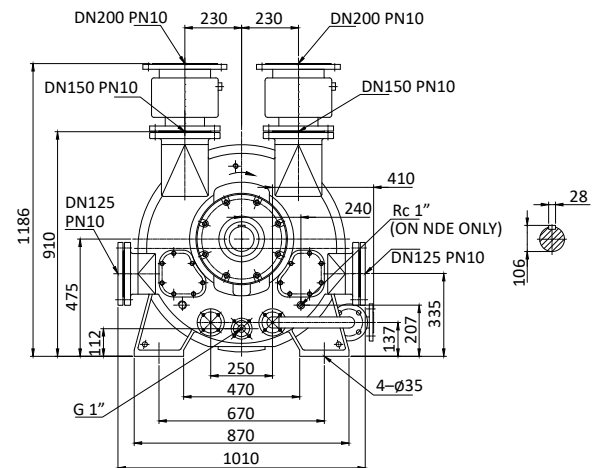

LR1A5500



MATERIALS OF CONSTRUCTION

Component	CI	CI/SS	SS 304	SS 316L
End casings	CI/HT200		SS 304	SS 316L
Manifold*	CS/Q235		SS 304	SS 316L
Port plates	CI/HT200		SS 304	SS 316L
Centre body	CS/Q235		SS 304	SS 316L
Impeller	Pheroidal graphite CI/QT400		SS 304	SS 316L
Shaft	CS/Q235		SS 2Cr13	
Sleeve	SS 304			SS 316L
O-ring	FKM			
Bearing housing	CI/HT200			
Valve plate	PTFE			
Shaft seals				
Single mechanical seal	Faces	SiC vs carbon		
	Elastomers	FKM		
	Metal parts	SS 316		
Gland packing*	PTFE fibre with graphite impregnation			
Double mechanical seal*	For details, contact Edwards			

*Optional configuration

TECHNICAL SPECIFICATIONS

Model	Capacity m ³ /h	Speed rpm	Flow rate m ³ /h	Motor rating kW	Ultimate vacuum mbara	Back pressure mbara	Weight kg	Noise dB(A)	Vibration mm/s
LR1A5500 (50/60 Hz)	5300	590	25	160	33	1300*	2175	85	4.5

* For higher back pressure, please consult Edwards.

PERFORMANCE CURVES

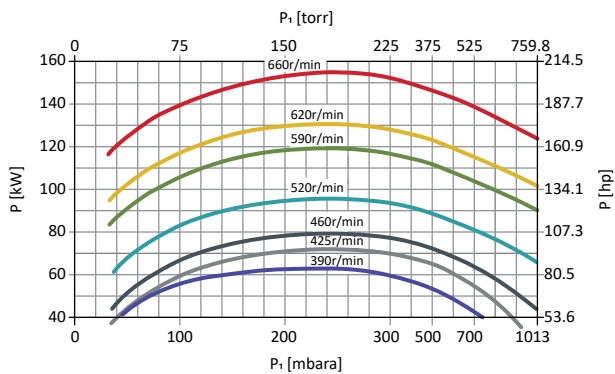
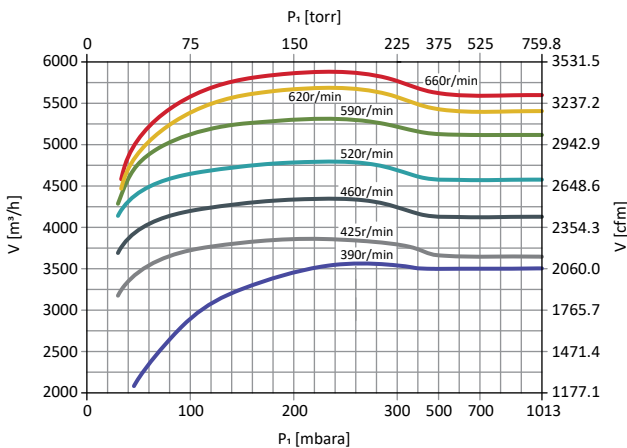

The performances shown are based on operating conditions with saturated air at 20 °C, service water at 15 °C, and exhaust pressure at the standard atmospheric pressure of 1,013.25 mbar. The performance tolerance is ±10%.

DIMENSIONS

All dimensions are in mm.

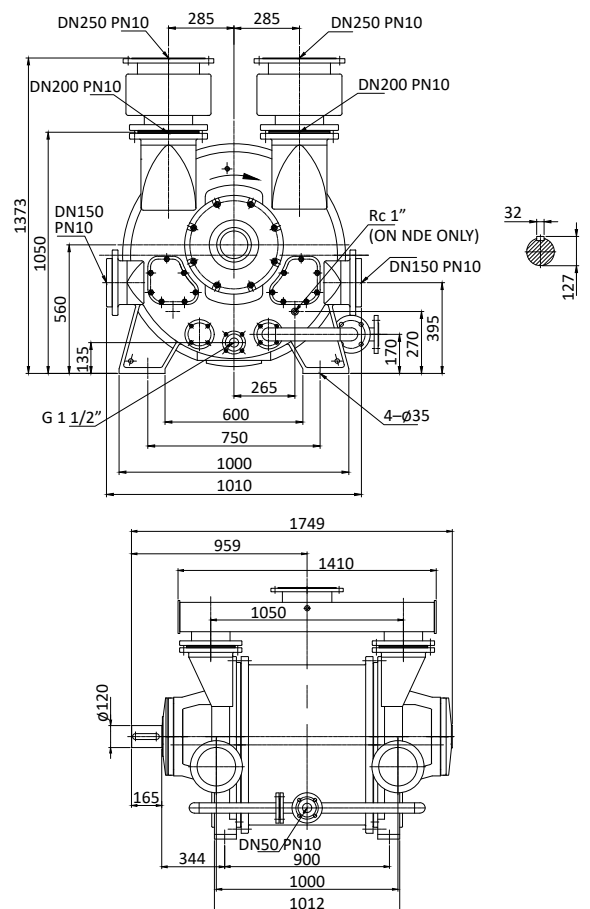

LR1A6500

MATERIALS OF CONSTRUCTION



Component	CI	CI/SS	SS 304	SS 316L
End casings	CI/HT200		SS 304	SS 316L
Manifold*	CS/Q235		SS 304	SS 316L
Port plates	CI/HT200		SS 304	SS 316L
Centre body	CS/Q235		SS 304	SS 316L
Impeller	Pheroidal graphite CI/QT400		SS 304	SS 316L
Shaft	CS/Q235		SS 2Cr13	
Sleeve	SS 304			SS 316L
O-ring	FKM			
Bearing housing	CI/HT200			
Valve plate	PTFE			
Shaft seals				
Single mechanical seal	Faces	SiC vs carbon		
	Elastomers	FKM		
	Metal parts	SS 316		
Gland packing*	PTFE fibre with graphite impregnation			
Double mechanical seal*	For details, contact Edwards			

*Optional configuration

TECHNICAL SPECIFICATIONS

Model	Capacity m ³ /h	Speed rpm	Flow rate m ³ /h	Motor rating kW	Ultimate vacuum mbara	Back pressure mbara	Weight kg	Noise dB(A)	Vibration mm/s
LR1A6500 (50/60 Hz)	6000	590	23.98	160	33	1300*	2661	85	4.5

* For higher back pressure, please consult Edwards.

PERFORMANCE CURVES

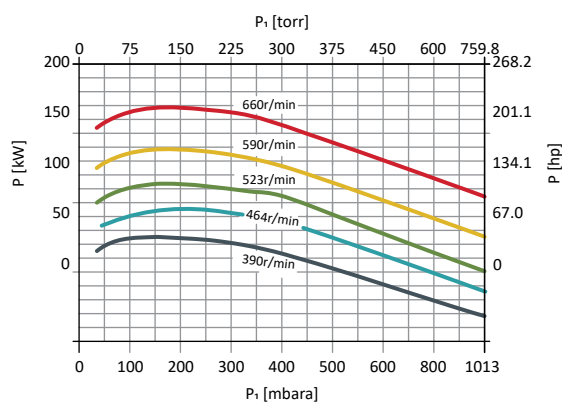
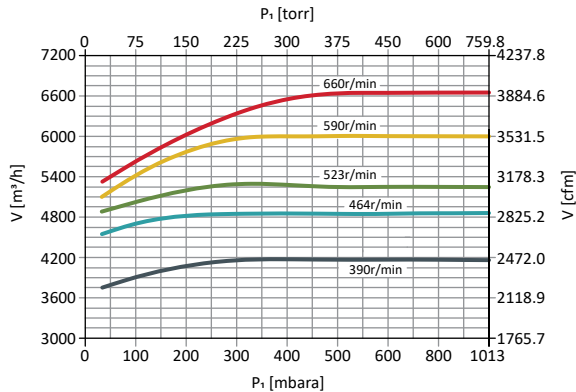

The performances shown are based on operating conditions with saturated air at 20 °C, service water at 15 °C, and exhaust pressure at the standard atmospheric pressure of 1,013.25 mbar. The performance tolerance is ±10%.

DIMENSIONS

All dimensions are in mm.

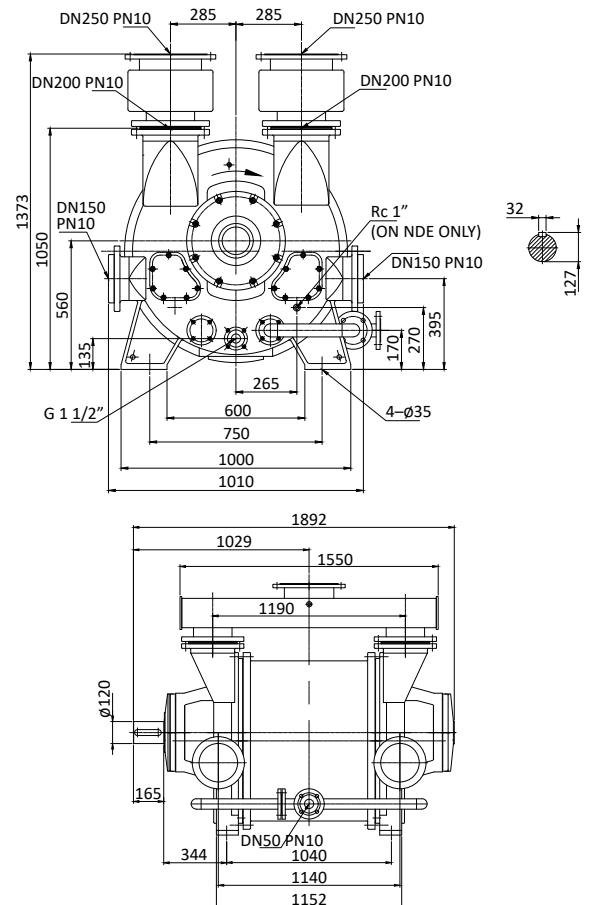

LR1A8000



MATERIALS OF CONSTRUCTION

Component	CI	CI/SS	SS 304	SS 316L
End casings	CI/HT200		SS 304	SS 316L
Manifold*	CS/Q235		SS 304	SS 316L
Port plates	CI/HT200		SS 304	SS 316L
Centre body	CS/Q235		SS 304	SS 316L
Impeller	Pheroidal graphite CI/QT400		SS 304	SS 316L
Shaft	CS/Q235		SS 2Cr13	
Sleeve	SS 304			SS 316L
O-ring	FKM			
Bearing housing	CI/HT200			
Valve plate	PTFE			
Shaft seals				
Single mechanical seal	Faces		SiC vs carbon	
	Elastomers		FKM	
	Metal parts		SS 316	
Gland packing*		PTFE fibre with graphite impregnation		
Double mechanical seal*		For details, contact Edwards		

*Optional configuration

TECHNICAL SPECIFICATIONS

Model	Capacity m ³ /h	Speed rpm	Flow rate m ³ /h	Motor rating kW	Ultimate vacuum mbara	Back pressure mbara	Weight kg	Noise dB(A)	Vibration mm/s
LR1A8000 (50/60 Hz)	8100	530	44	250	33	1300*	3343	85	4.5

* For higher back pressure, please consult Edwards.

PERFORMANCE CURVES

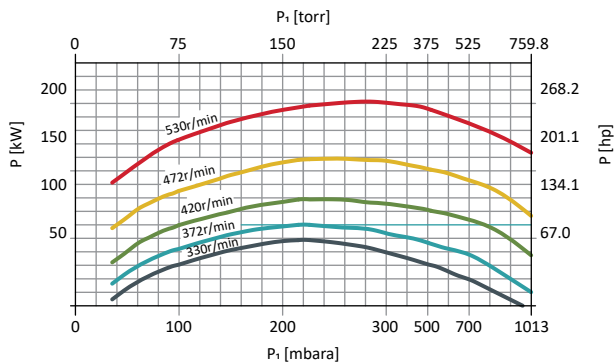
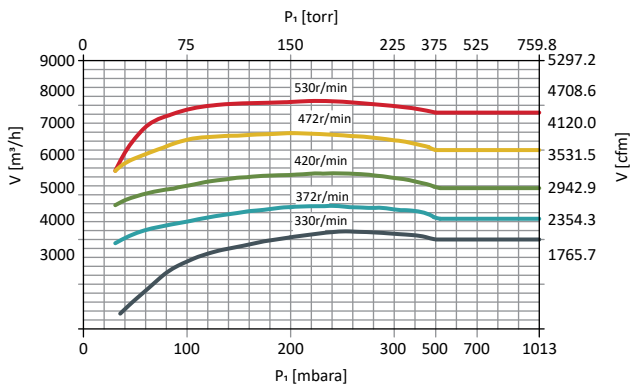

The performances shown are based on operating conditions with saturated air at 20 °C, service water at 15 °C, and exhaust pressure at the standard atmospheric pressure of 1,013.25 mbar. The performance tolerance is ±10%.

DIMENSIONS

All dimensions are in mm.

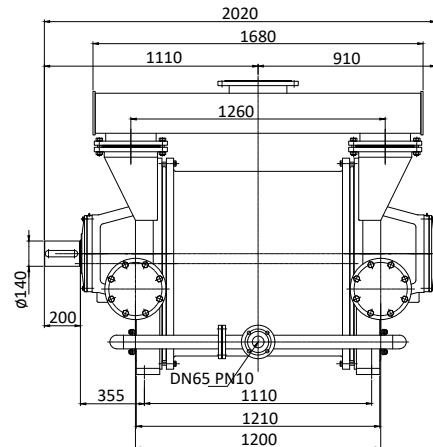
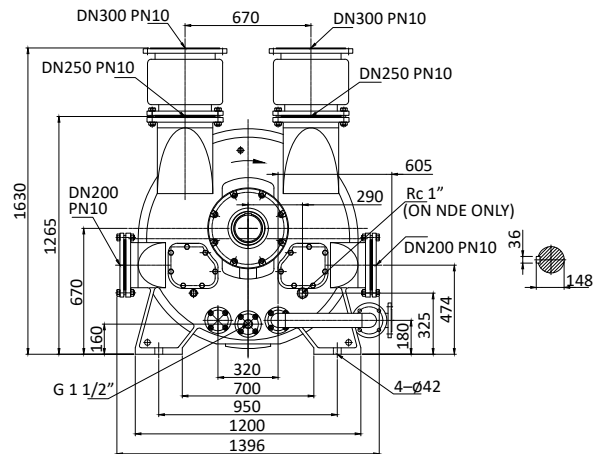

LR1A10000



MATERIALS OF CONSTRUCTION

Component	CI	CI/SS	SS 304	SS 316L
End casings	CI/HT200		SS 304	SS 316L
Manifold*	CS/Q235		SS 304	SS 316L
Port plates	CI/HT200		SS 304	SS 316L
Centre body	CS/Q235		SS 304	SS 316L
Impeller	Pheroidal graphite CI/QT400		SS 304	SS 316L
Shaft	CS/Q235		SS 2Cr13	
Sleeve		SS 304		SS 316L
O-ring			FKM	
Bearing housing		CI/HT200		
Valve plate			PTFE	
Shaft seals				
Single mechanical seal	Faces	SiC vs carbon		
	Elastomers	FKM		
	Metal parts	SS 316		
Gland packing*	PTFE fibre with graphite impregnation			
Double mechanical seal*	For details, contact Edwards			

*Optional configuration

TECHNICAL SPECIFICATIONS

Model	Capacity m ³ /h	Speed rpm	Flow rate m ³ /h	Motor rating kW	Ultimate vacuum mbara	Back pressure mbara	Weight kg	Noise dB(A)	Vibration mm/s
LR1A10000 (50/60 Hz)	9450	530	38	250	33	1300*	3471	85	4.5

* For higher back pressure, please consult Edwards.

PERFORMANCE CURVES

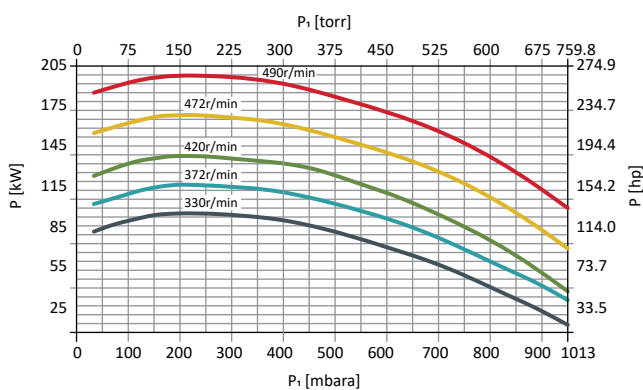
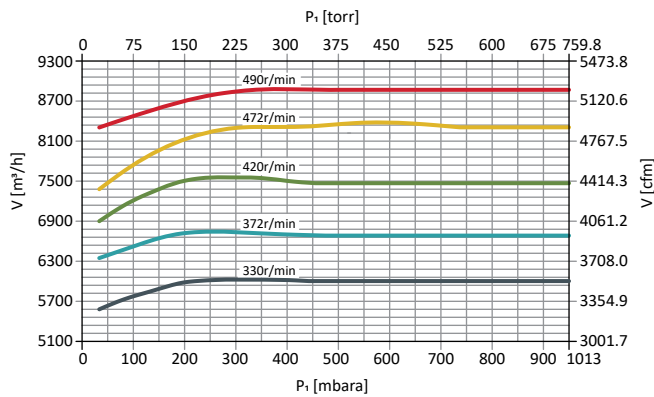

The performances shown are based on operating conditions with saturated air at 20 °C, service water at 15 °C, and exhaust pressure at the standard atmospheric pressure of 1,013.25 mbar. The performance tolerance is ±10%.

DIMENSIONS

All dimensions are in mm.

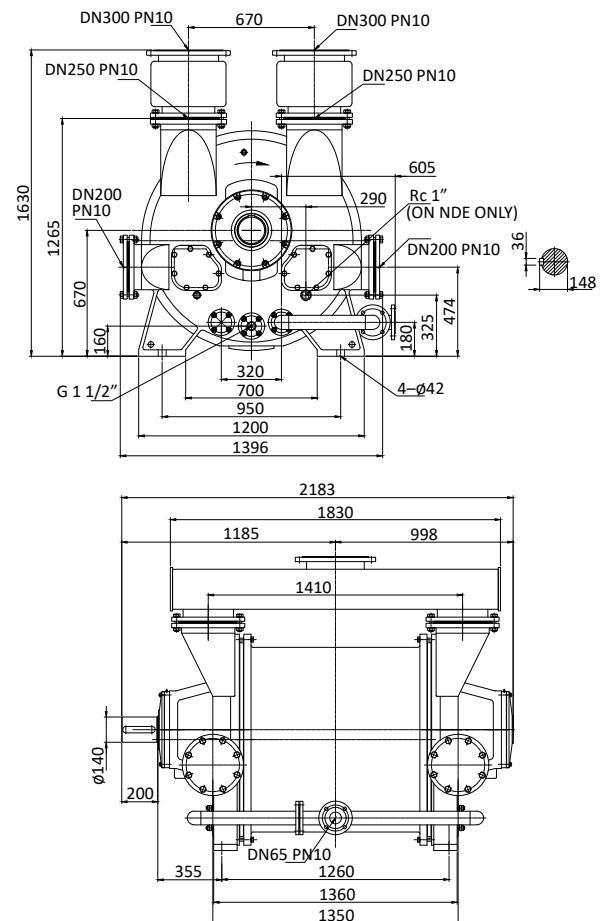

LR1A12000



MATERIALS OF CONSTRUCTION

Component	CI	CI/SS	SS 304	SS 316L
End casings	CI/HT200		SS 304	SS 316L
Manifold*	CS/Q235		SS 304	SS 316L
Port plates	CI/HT200		SS 304	SS 316L
Centre body	CS/Q235		SS 304	SS 316L
Impeller	Pheroidal graphite CI/QT400		SS 304	SS 316L
Shaft	CS/Q235		SS 2Cr13	
Sleeve		SS 304		SS 316L
O-ring		FKM		
Bearing housing		CI/HT200		
Valve plate		PTFE		
Shaft seals				
Single mechanical seal	Faces	SiC vs carbon		
	Elastomers	FKM		
	Metal parts	SS 316		
Gland packing*	PTFE fibre with graphite impregnation			
Double mechanical seal*	For details, contact Edwards			

*Optional configuration

TECHNICAL SPECIFICATIONS

Model	Capacity m ³ /h	Speed rpm	Flow rate m ³ /h	Motor rating kW	Ultimate vacuum mbara	Back pressure mbara	Weight kg	Noise dB(A)	Vibration mm/s
LR1A12000 (50/60 Hz)	11652	472	44.6	355	33	1300*	4351	85	4.5

* For higher back pressure, please consult Edwards.

PERFORMANCE CURVES

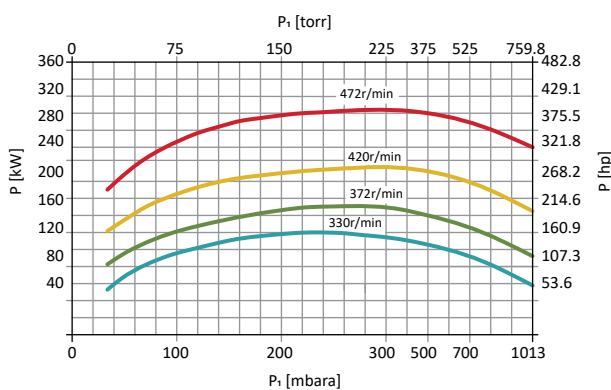
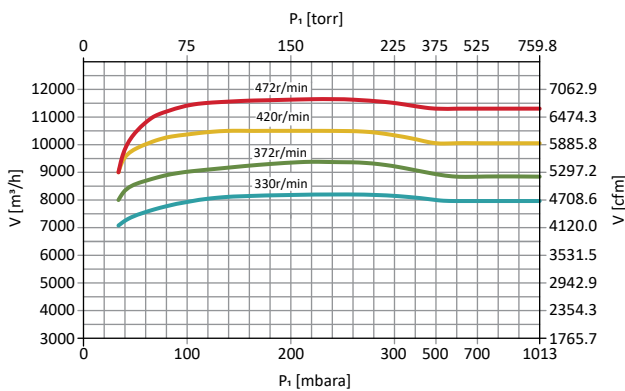

The performances shown are based on operating conditions with saturated air at 20 °C, service water at 15 °C, and exhaust pressure at the standard atmospheric pressure of 1,013.25 mbar. The performance tolerance is ±10%.

DIMENSIONS

All dimensions are in mm.

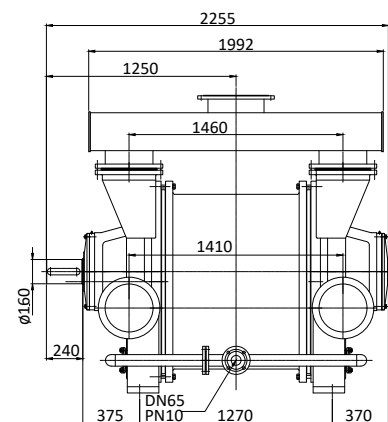
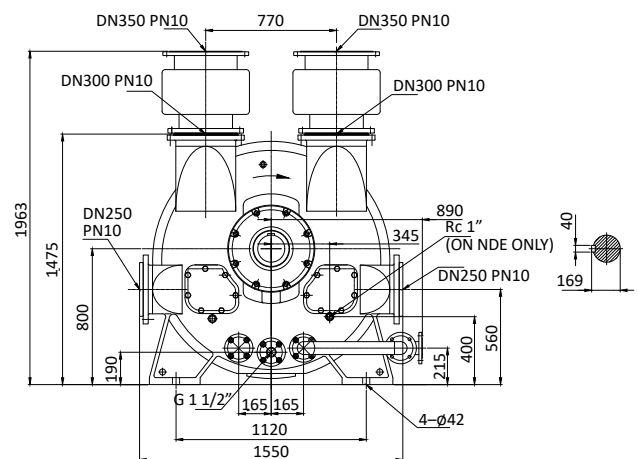

LR1A13000



MATERIALS OF CONSTRUCTION

Component	CI	CI/SS	SS 304	SS 316L
End casings	CI/HT200		SS 304	SS 316L
Manifold*	CS/Q235		SS 304	SS 316L
Port plates	CI/HT200		SS 304	SS 316L
Centre body	CS/Q235		SS 304	SS 316L
Impeller	Pheroidal graphite CI/QT400		SS 304	SS 316L
Shaft	CS/Q235		SS 2Cr13	
Sleeve		SS 304		SS 316L
O-ring		FKM		
Bearing housing		CI/HT200		
Valve plate		PTFE		
Shaft seals				
Single mechanical seal	Faces	SiC vs carbon		
	Elastomers	FKM		
	Metal parts	SS 316		
Gland packing*	PTFE fibre with graphite impregnation			
Double mechanical seal*	For details, contact Edwards			

*Optional configuration

TECHNICAL SPECIFICATIONS

Model	Capacity m ³ /h	Speed rpm	Flow rate m ³ /h	Motor rating kW	Ultimate vacuum mbara	Back pressure mbara	Weight kg	Noise dB(A)	Vibration mm/s
LR1A13000 (50/60 Hz)	11820	420	48.2	280	160	1300*	4538	85	4.5

* For higher back pressure, please consult Edwards.

PERFORMANCE CURVES

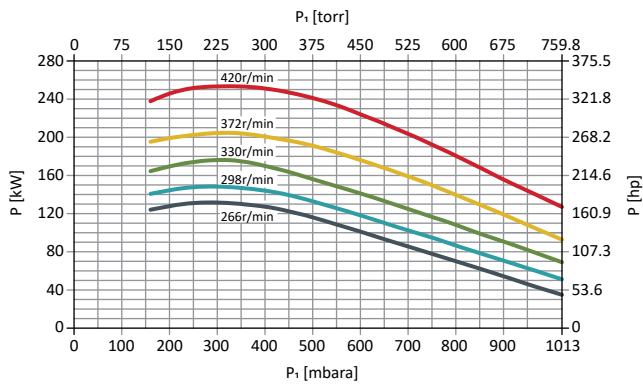
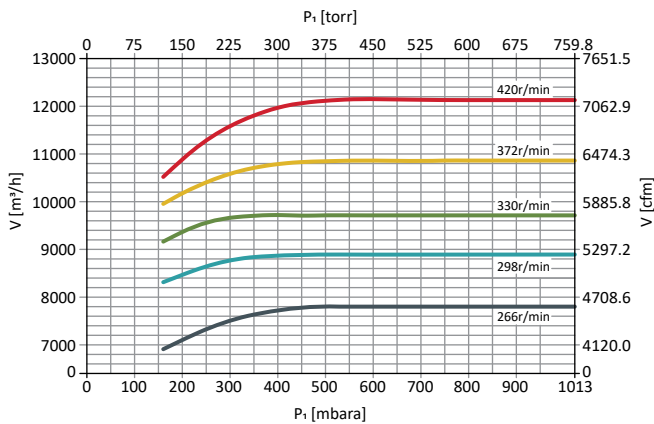

The performances shown are based on operating conditions with saturated air at 20 °C, service water at 15 °C, and exhaust pressure at the standard atmospheric pressure of 1,013.25 mbar. The performance tolerance is ±10%.

DIMENSIONS

All dimensions are in mm.

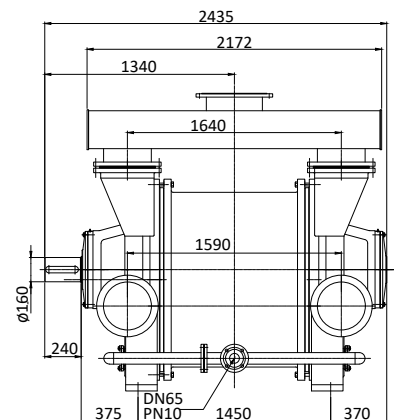
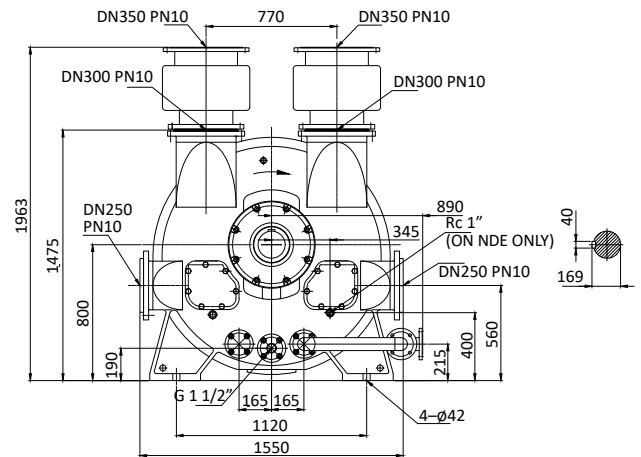

LR1A16000



MATERIALS OF CONSTRUCTION

Component	CI	CI/SS	SS 304	SS 316L
End casings	CI/HT200		SS 304	SS 316L
Manifold*	CS/Q235		SS 304	SS 316L
Port plates	CI/HT200		SS 304	SS 316L
Centre body	CS/Q235		SS 304	SS 316L
Impeller	Pheroidal graphite CI/QT400		SS 304	SS 316L
Shaft	CS/Q235		SS 2Cr13	
Sleeve	SS 304			SS 316L
O-ring	FKM			
Bearing housing	CI/HT200			
Valve plate	PTFE			
Shaft seals				
Single mechanical seal	Faces		SiC vs carbon	
	Elastomers		FKM	
	Metal parts		SS 316	
Gland packing*		PTFE fibre with graphite impregnation		
Double mechanical seal*		For details, contact Edwards		

*Optional configuration

TECHNICAL SPECIFICATIONS

Model	Capacity m ³ /h	Speed rpm	Flow rate m ³ /h	Motor rating kW	Ultimate vacuum mbara	Back pressure mbara	Weight kg	Noise dB(A)	Vibration mm/s
LR1A16000 (50/60 Hz)	16380	398	63.4	450	33	1300*	6895	85	4.5

* For higher back pressure, please consult Edwards.

PERFORMANCE CURVES

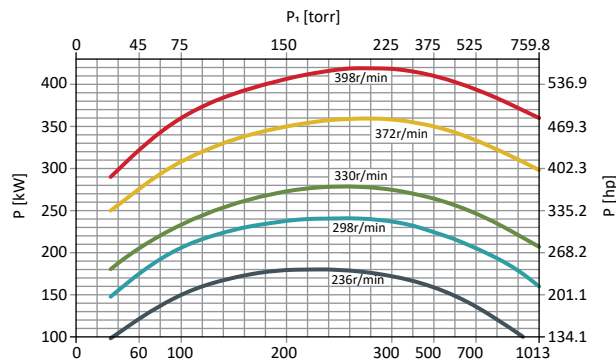
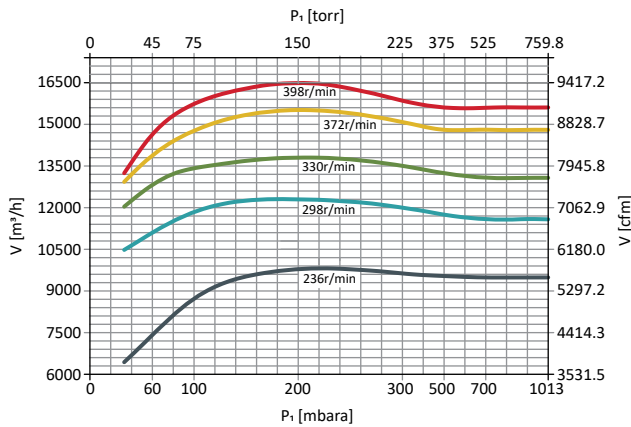

The performances shown are based on operating conditions with saturated air at 20 °C, service water at 15 °C, and exhaust pressure at the standard atmospheric pressure of 1,013.25 mbar. The performance tolerance is ±10%.

DIMENSIONS

All dimensions are in mm.

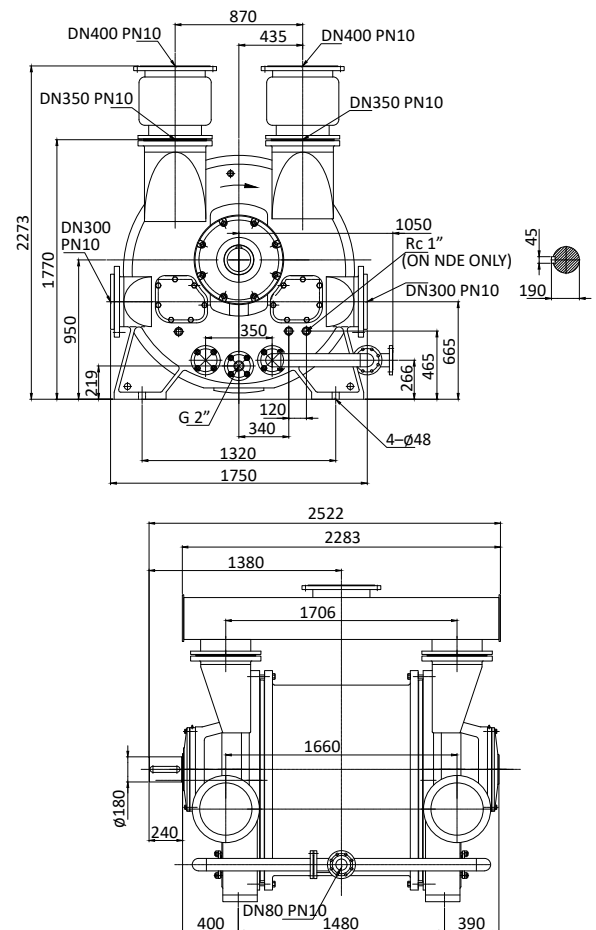

LR1A19000

MATERIALS OF CONSTRUCTION

Component	CI	CI/SS	SS 304	SS 316L
End casings	CI/HT200		SS 304	SS 316L
Manifold*	CS/Q235		SS 304	SS 316L
Port plates	CI/HT200		SS 304	SS 316L
Centre body	CS/Q235		SS 304	SS 316L
Impeller	Pheroidal graphite CI/QT400		SS 304	SS 316L
Shaft	CS/Q235		SS 2Cr13	
Sleeve		SS 304		SS 316L
O-ring		FKM		
Bearing housing		CI/HT200		
Valve plate		PTFE		
Shaft seals				
Single mechanical seal	Faces	SiC vs carbon		
	Elastomers	FKM		
	Metal parts	SS 316		
Gland packing*	PTFE fibre with graphite impregnation			
Double mechanical seal*	For details, contact Edwards			

*Optional configuration

TECHNICAL SPECIFICATIONS

Model	Capacity m ³ /h	Speed rpm	Flow rate m ³ /h	Motor rating kW	Ultimate vacuum mbara	Back pressure mbara	Weight kg	Noise dB(A)	Vibration mm/s
LR1A19000 (50/60 Hz)	18250	398	76	500	160	1300*	7192	85	4.5

* For higher back pressure, please consult Edwards.

PERFORMANCE CURVES

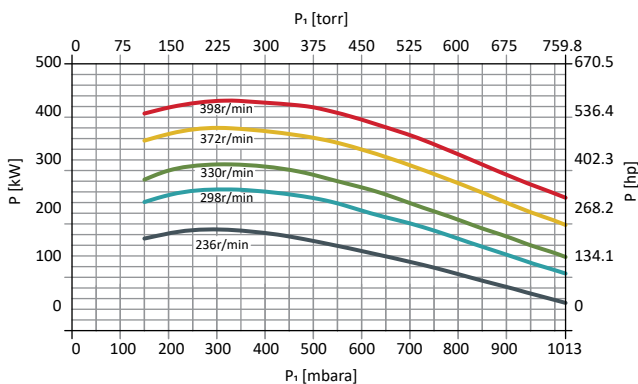
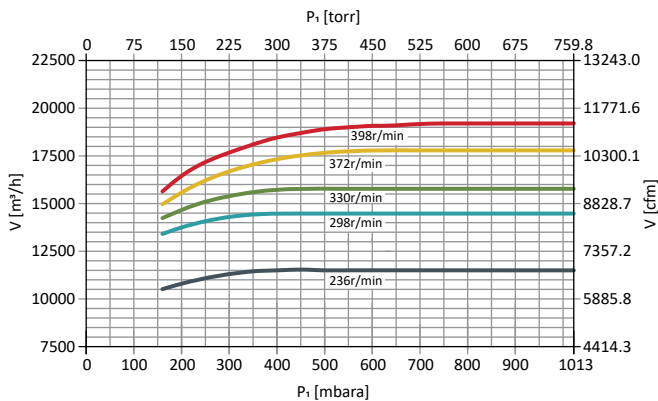

The performances shown are based on operating conditions with saturated air at 20 °C, service water at 15 °C, and exhaust pressure at the standard atmospheric pressure of 1,013.25 mbar. The performance tolerance is ±10%.

DIMENSIONS

All dimensions are in mm.

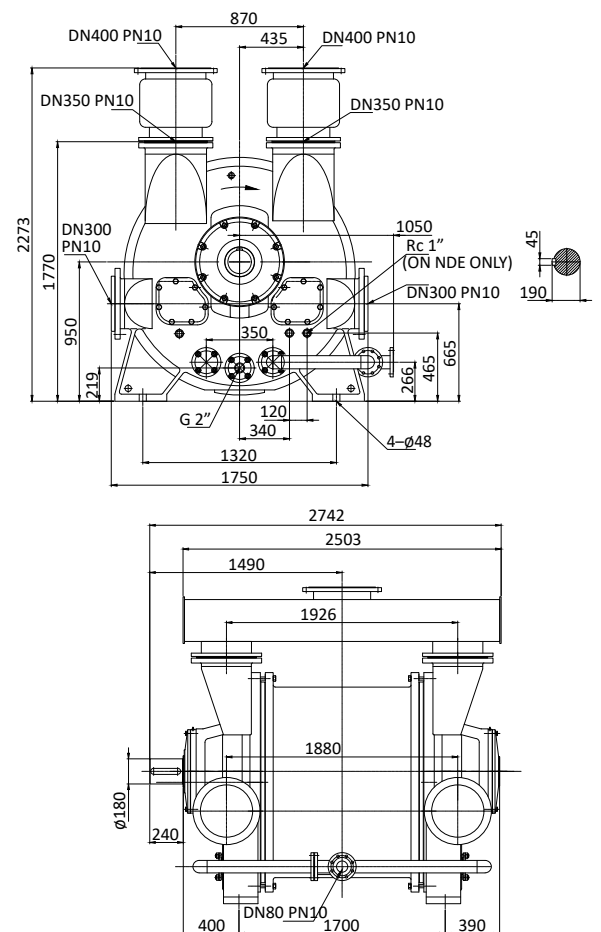

LR1A23000



MATERIALS OF CONSTRUCTION

Component	CI	CI/SS	SS 304	SS 316L
End casings	CI/HT200		SS 304	SS 316L
Manifold*	CS/Q235		SS 304	SS 316L
Port plates	CI/HT200		SS 304	SS 316L
Centre body	CS/Q235		SS 304	SS 316L
Impeller	Pheroidal graphite CI/QT400		SS 304	SS 316L
Shaft	CS/Q235		SS 2Cr13	
Sleeve	SS 304			SS 316L
O-ring	FKM			
Bearing housing	CI/HT200			
Valve plate	PTFE			
Shaft seals				
Single mechanical seal	Faces	SiC vs carbon		
	Elastomers	FKM		
	Metal parts	SS 316		
Gland packing*	PTFE fibre with graphite impregnation			
Double mechanical seal*	For details, contact Edwards			

*Optional configuration

TECHNICAL SPECIFICATIONS

Model	Capacity m ³ /h	Speed rpm	Flow rate m ³ /h	Motor rating kW	Ultimate vacuum mbara	Back pressure mbara	Weight kg	Noise dB(A)	Vibration mm/s
LR1A23000 (50/60 Hz)	22800	330	85.6	630	33	1300*	9752	85	4.5

* For higher back pressure, please consult Edwards.

PERFORMANCE CURVES

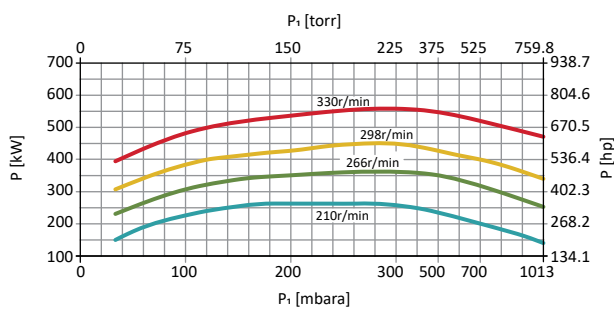
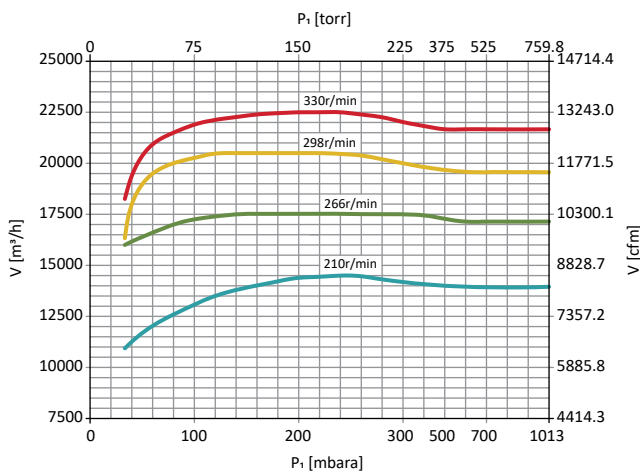

The performances shown are based on operating conditions with saturated air at 20 °C, service water at 15 °C, and exhaust pressure at the standard atmospheric pressure of 1,013.25 mbar. The performance tolerance is ±10%.

DIMENSIONS

All dimensions are in mm.

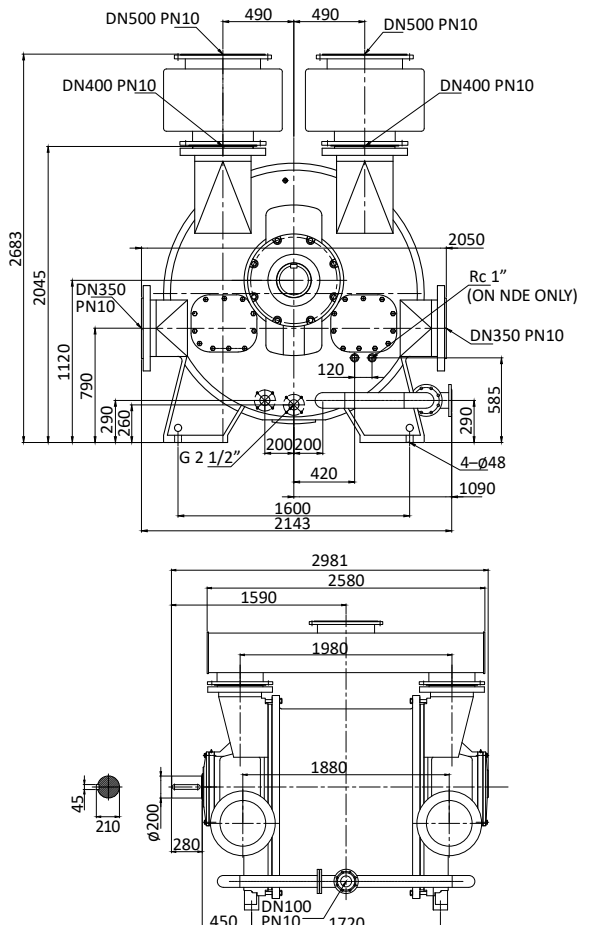

LR1A26000



MATERIALS OF CONSTRUCTION

Component	CI	CI/SS	SS 304	SS 316L
End casings	CI/HT200		SS 304	SS 316L
Manifold*	CS/Q235		SS 304	SS 316L
Port plates	CI/HT200		SS 304	SS 316L
Centre body	CS/Q235		SS 304	SS 316L
Impeller	Pheroidal graphite CI/QT400		SS 304	SS 316L
Shaft	CS/Q235		SS 2Cr13	
Sleeve		SS 304		SS 316L
O-ring		FKM		
Bearing housing		CI/HT200		
Valve plate		PTFE		
Shaft seals				
Single mechanical seal	Faces	SiC vs carbon		
	Elastomers	FKM		
	Metal parts	SS 316		
Gland packing*	PTFE fibre with graphite impregnation			
Double mechanical seal*	For details, contact Edwards			

*Optional configuration

TECHNICAL SPECIFICATIONS

Model	Capacity m ³ /h	Speed rpm	Flow rate m ³ /h	Motor rating kW	Ultimate vacuum mbara	Back pressure mbara	Weight kg	Noise dB(A)	Vibration mm/s
LR1A26000 (50/60 Hz)	26000	330	104	710	160	1300*	10149	85	4.5

* For higher back pressure, please consult Edwards.

PERFORMANCE CURVES

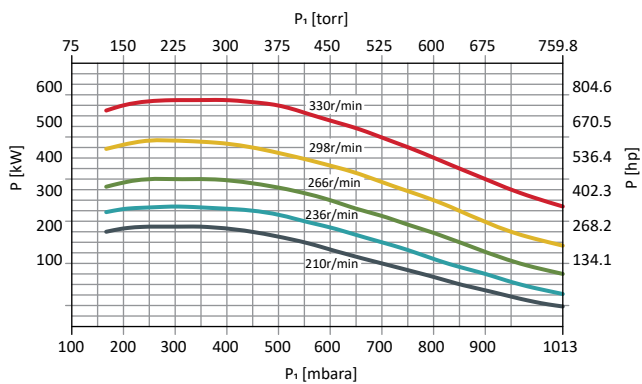
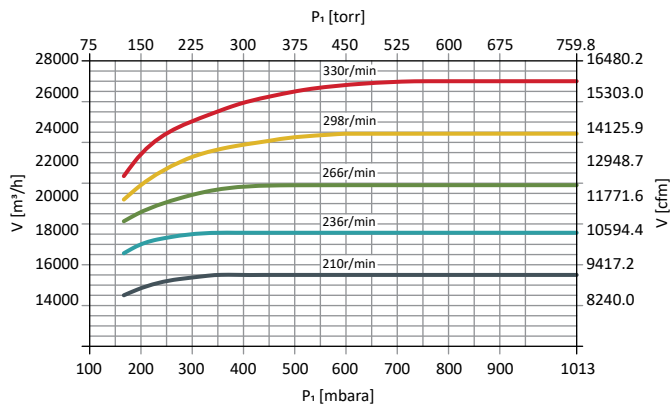

The performances shown are based on operating conditions with saturated air at 20 °C, service water at 15 °C, and exhaust pressure at the standard atmospheric pressure of 1,013.25 mbar. The performance tolerance is ±10%.

DIMENSIONS

All dimensions are in mm.

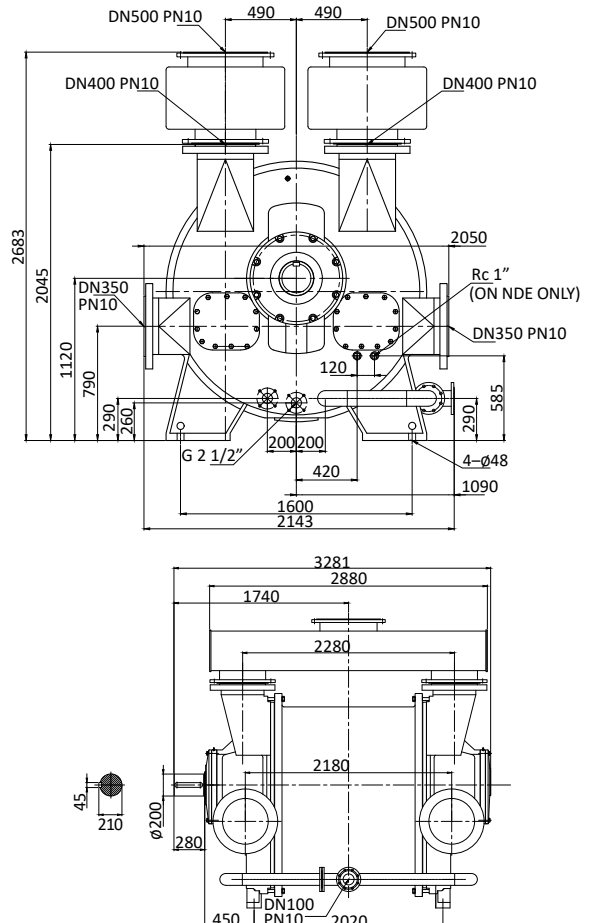

APPLICATIONS



- Chemical industries
- Oil and gas
- Petroleum industries
- Cement and allied products
- General manufacturing
- Metalwork industries
- Mining
- Paper and pulp
- Plastic and compound
- Power and energy
- Textile industry



SERVICE AND SUPPORT

To ensure your pump maintains optimal performance and reliability, we offer a wide range of service solutions, tailored to meet your needs. From Field Service intervention to Managed Maintenance agreements, we will take care of your pump to ensure that it continues to deliver clean, consistent, efficient performance, with lower running cost and optimum total cost of ownership for its entire operating life.

Selecting original spare parts, maintenance kits and grease, means that every critical part performs as it was intended. Form, fit and function are guaranteed. Our services engineers only fit 100% genuine parts to ensure you receive the best result from each and every service.

Contact your local Edwards sales office to discuss your specific requirements.





Publication Number: 3602 705 2 01
© Edwards Limited 2022. All rights reserved.
Edwards and the Edwards logo are trademarks of
Edwards Limited.

Whilst we make every effort to ensure that we
accurately describe our products and services,
we give no guarantee as to the accuracy or
completeness of any information provided in
this brochure.

Edwards Ltd., registered in England and Wales
No. 6124750, registered office: Innovation Drive,
Burgess Hill, West Sussex, RH15 9TW, UK.