

Models

A5 A10 A15 A20

Features

- No contact between operating components in the casing
- Flat power curve over entire vacuum range prevents motor overload
- Reduced stress on motor shaft and bearings
- Increased water handling capability prevents heat build-up, extends life of mechanical seals
- Compact, close-coupled design eliminates need for inter-stage manifold or motor alignment
- Shrouded rotor increases pumping efficiency for high vacuum and low water consumption
- Fast delivery on standard materials and local support



Materials of Construction

Casing, Cover, Rotor, Port Cylinder:

- All Bronze
- Cast Iron, Bronze Fitted
- Cast Iron, Stainless Steel Fitted (A10-A20)
- All Stainless Steel (A10 – A20)

Mechanical Seals:

- Viton™ — Cast Iron Bronze Fitted, All Bronze, Stainless Steel
- EPR — Optional
- Kalrez™ — Optional

Drive Options:

- Pedestal Frame
- Close-coupled motor

Stocked Motors:

- TEFC – 3Ø
- TEFC – 1Ø

Optional Motors:

- XP Class I, GpD – 3Ø — Optional
- XP Class I, GpD – 1Ø — Optional

Typical Pumping Speed Curves

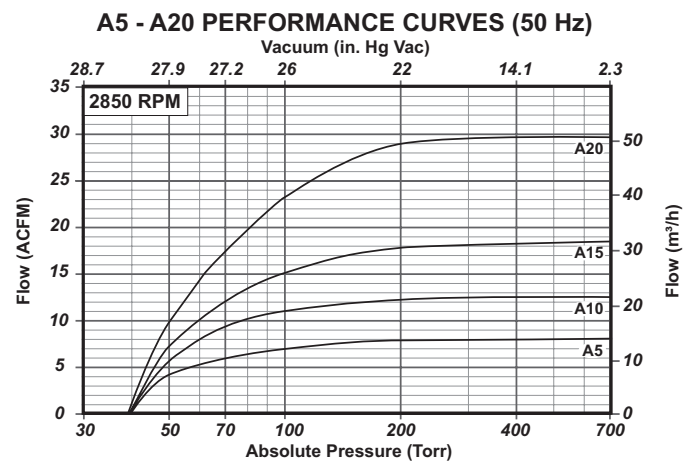
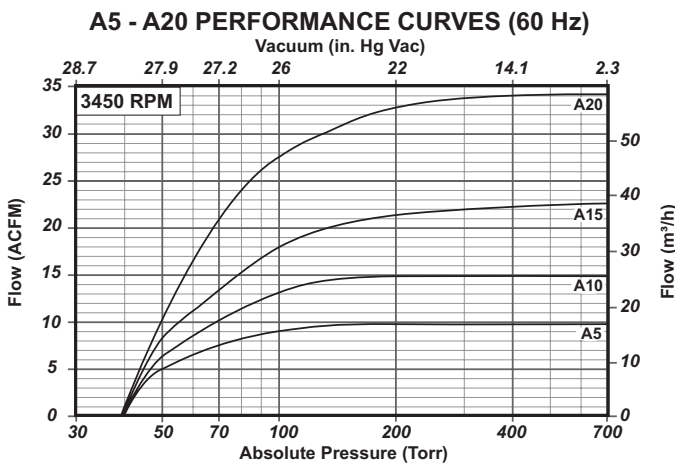

Dimensions

Values shown are approximate and should not be used for construction.
 Certified drawings are available through your local Tuthill Vacuum & Blower Systems Sales Professional.

Close-coupled Design

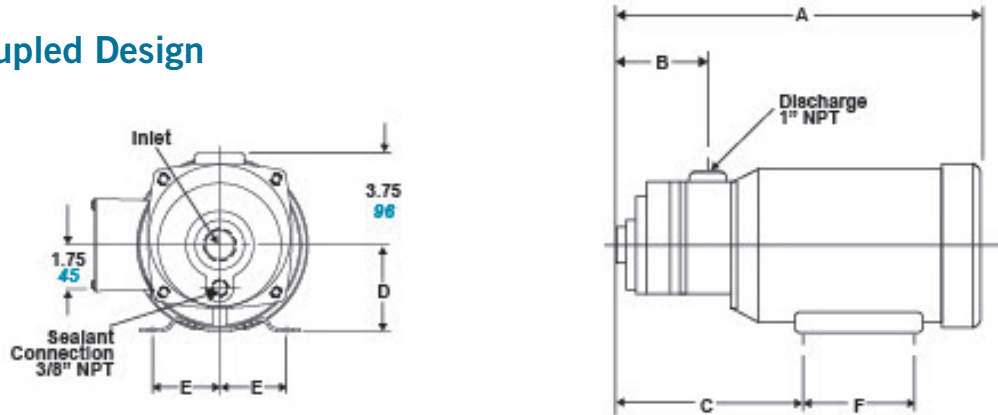

MODEL	FRAME	INLET NPT	inches/mm						MOTOR HP	Weight (lbs./kg)
			A	B	C	D	E	F		
A5	56CZ	3/4"	14.0 / 356	2.9 / 74	6.7 / 170	3.5 / 89	2.44 / 62	3.0 / 76	1	50 / 23
A10	145TCZ	1"	16.6 / 422	3.6 / 92	8.0 / 203	3.5 / 89	2.75 / 70	5.0 / 127	1 1/2	62 / 28
A15	145TCZ	1"	17.0 / 432	3.8 / 97	8.3 / 211	3.5 / 89	2.75 / 70	5.0 / 127	2	69 / 31
A20	182CZ	1"	18.5 / 470	4.6 / 117	9.6 / 244	4.5 / 114	3.75 / 95	5.5 / 140	3	85 / 39

Pedestal Mount Design

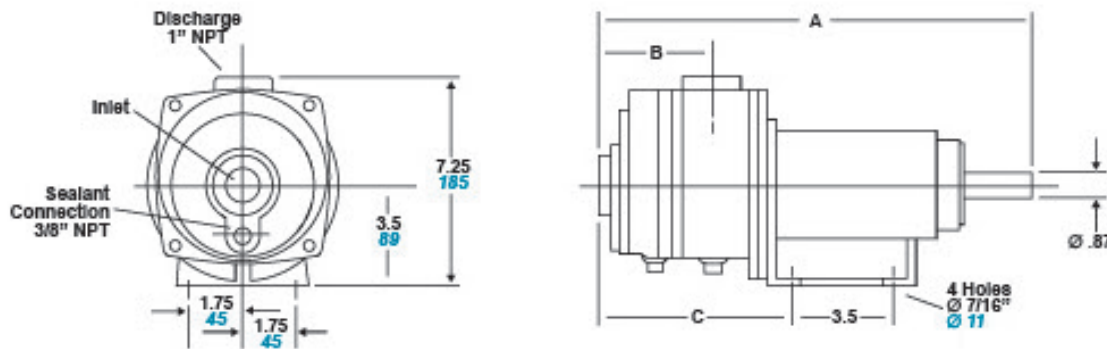

MODEL	INLET NPT	inches/mm			Weight (lbs./kg)
		A	B	C	
A10	1"	14.52 / 369	3.52 / 89	6.20 / 157	42 / 19
A15	1"	14.83 / 377	3.83 / 97	6.51 / 165	44 / 20
A20	1"	15.60 / 396	4.60 / 117	7.28 / 185	48 / 22

Your Local Tuthill Vacuum Blower Systems Sales Professional:



Western Washington: 253-740-0530
 Eastern Washington: 509-949-3368
 Idaho & Montana: 208-360-3833
 Oregon: 503-708-9609
info@nwflowtech.com



Tuthill Vacuum & Blower Systems
 4840 West Kearney Street
 Springfield, Missouri USA 65803-8702
 o 417.865.8715 800.825.6937 f 417.865.2950
tuthillvacuumblower.com

