

CP Series

CP Series rotary blowers are designed to be interchangeable with equivalent sizes of Roots Universal RAI®, and many Sutorbilt® Legend® blowers. CP Series models are rated up to 15 PSIG discharge pressure or 16" Hg dry vacuum. All models have sight glasses and triple lip seals as standard features.

Reduced Noise Versions Available

CP Series standard models feature a bi-lobe design. Many models are available with tri-lobe rotors and a specially tuned housing to reduce blower noise.

Triple Lip Seals

Standard on all models, triple lip seals provide improved lubrication to extend the life of the seal up to 50% also resulting in longer bearing life.

Helical Gearing

CP Series blowers are timed with precision helical gears, keyed to the rotor shafts, not taper fit spur gears as offered by other manufacturers, which have greater backlash, can slip and lose timing. Helical gears are also quieter, reducing mechanical noise.

Stronger Bearings

All CP Series blowers include double-row ball bearings at the gear end, stronger than single row ball bearings offered by other manufacturers. Drive shaft bearing is cylindrical roller type for additional strength against side loading from V-belt drives. As a result of this superior design, CP Series blowers offer design bearing life as much as 50% greater than models offered by other manufacturers.

Rotors with Integral Shafts

CP Series blowers include precision machined ductile iron rotors with large, integrally cast shafts, not press fit and/or pinned shafts offered by other manufacturers, which can loosen over time and cause rotor clash.

Versatility

CP Series blowers can be field converted from horizontal to vertical flow, or vice versa, without any special tools or additional components.



Metric Availability

CP Series blowers are available with metric drive shaft and process connections.

Lubrication

Many CP Series models include dual oil splash lubrication at both the gear end and drive end of the blower. Splash lubrication provides for longer bearing and seal life through improved heat dissipation versus grease lubrication.

Material Specifications:

Housing: Cast iron

End Plates: Cast iron

End Cover: Cast iron

Rotors: Ductile iron

Shafts: Ductile iron, cast integrally with rotors

Bearings: Gear end - Double row ball, both rotors

Drive end - Cylindrical roller on drive rotor

Single row ball on driven rotor

Drive Shaft: Ductile iron, cast integrally with drive rotor

Gears: Heat treated alloy steel, helical cut

Seals: Lip seals on rotor shafts and drive shaft

Lubrication: Oil splash on gear end, grease on drive end

Models available with dual oil splash lubrication

Performance continued

Model	Lobe	RPM	6 psig		7 psig		8 psig		10 psig		12 psig		13 psig		14 psig		15 psig		16 psig		17 psig		18 psig		Max. Vacuum		
			CFM	BHP	CFM	BHP	CFM	BHP	CFM	BHP	CFM	BHP	CFM	BHP	CFM	BHP	CFM	BHP	CFM	BHP	CFM	BHP	CFM	BHP	" Hg	CFM	BHP
6015	2-lobe	700	273	13.9	254	16.2																		10	247	11.5	
6015	2-lobe	1760	1058	35.0	1038	40.7																		14	943	40.0	
6015	2-lobe	2350	1494	46.8	1475	54.4																		14	1380	53.4	
7006	2-lobe	650	171	7.2	163	8.3	157	9.5	144	11.8	133	14.0	128	15.2											13	137	7.6
7006	2-lobe	1760	617	19.5	610	22.6	603	25.7	591	31.8	579	38.0	574	41.1	569	44.2	564	47.3							16	556	25.2
7006	2-lobe	2050	734	22.7	726	26.3	719	29.9	707	37.1	696	44.3	691	47.8	686	51.4	681	55.0							16	672	29.4
7011	2-lobe	650	322	12.9	310	15.0	298	17.1	277	21.3															13	264	13.7
7011	2-lobe	1760	1142	35.0	1129	40.6	1117	46.3	1096	57.6															16	1035	45.5
7011	2-lobe	2050	1356	40.7	1343	47.3	1331	53.9	1310	67.1															16	1249	53.0
7018	2-lobe	650	560	20.8																					10	536	17.1
7018	2-lobe	1760	1892	56.2																					12	1830	55.3
7018	2-lobe	2050	2240	65.5																					12	2178	64.4

Dimensions: Standard Models/6

Model Size	A	B	C	D	E	F	G1	G2	H	J1	J2	K	L1	L2	M	N1	N2	N3	P	R	S	T	U	V	Weight (lbs.)
2002	10.13	5.00	2.63		1" NPT	2.00	1.75	1.75	5.06	6.88	9.69	3.13	5.13	5.13	.63	3.75	6.25	3.75	9.38	1.25	5.00	1.25	5/8"	.625	41
2004	12.13	6.00	3.63	2.50	2" NPT	3.00	1.75	-	7.06	6.88	9.69	3.13	5.13	5.13	.63	3.75	6.25	3.75	9.38	1.25	5.00	1.25	5/8"	.625	53
3002	11.50	5.69	3.38		1 1/4" NPT	2.69			6.75	8.94	12.81	3.94	7.25	7.25	5.00	5.00	8.50	5.00	12.19	1.75	6.75	1.75	3/4"	.875	78
3003	12.38	6.13	3.81	2.44	2" NPT	3.13	2.69	2.69	7.63	8.94	12.81	3.94	7.25	7.25	5.00	5.00	8.50	5.00	12.19	1.75	6.75	1.75	3/4"	.875	83
3006	14.75	7.31	5		2 1/2" NPT	4.31			10.00	8.94	12.81	3.94	7.25	7.25	5.00	5.00	8.50	5.00	12.19	1.75	6.75	1.75	3/4"	.875	113
4002	12.94	6.25	3.69		1 1/2" NPT	2.75			7.25	8.94	12.81	3.94	7.25	7.25	5.00	5.00	8.50	5.00	12.19	1.75	6.75	1.75	3/4"	.875	95
4005	15.69	7.63	5.06	3.00	2 1/2" NPT	4.13	3.07	3.07	10.00	10.63	15.13	4.38	8.00	8.00	6.25	6.25	10.25	6.25	13.69	2.00	8.25	2.00	1/2"	.875	119
4007	17.44	8.50	5.94		3" NPT	5.00			11.75	10.63	15.13	4.38	8.00	8.00	6.25	6.25	10.25	6.25	13.69	2.00	8.25	2.00	1/2"	.875	138
5003	15.25	7.38	4.50		2 1/2" NPT	3.50			8.44	10.63	15.13	4.38	8.00	8.00	6.25	6.25	10.25	6.25	13.69	2.00	8.25	2.00	1/2"	.875	152
5006	17.88	8.69	5.81	3.38	4" NPT	4.81	3.50	3.50	11.06	12.13	17.38	5.38	10.50	10.50	6.75	6.75	11.25	6.25	17.19	2.50	8.75	1.88	5/8"	1.125	185
5009	20.88	10.19	7.31		4" NPT	6.25			14.06	12.13	17.38	5.38	10.50	10.50	6.75	6.75	11.25	6.25	17.19	2.50	8.75	1.88	5/8"	1.125	222
6005	18.69	9.38	5.63		3" NPT	4.25	4.13	4.06	10.00	15.00	21.69	6.25	17.06	11.00	8.75	8.75	14.75	8.75	19.81	3.00	11.75	2.13	3/4"	1.375	250
6008	21.69	10.88	7.13	3.69	5" NPT	5.75	7.13	4.06	13.00	15.00	21.69	6.25	17.06	11.00	8.75	8.75	14.75	8.75	19.81	3.00	11.75	2.13	3/4"	1.375	310
6015	28.69	14.38	10.63		6" FLG	9.25			20.00	16.25	26.13	8.50	21.06	14.00	11.00	11.00	18.00	11.00	23.25	3.50	14.50	2.38	3/4"	1.562	456
7006	20.31	10.31	5.94		4" NPT	4.88	5.50	7.17	11.75	20.69	26.13	8.50	21.06	14.00	11.00	11.00	18.00	11.00	23.25	3.50	14.50	2.38	3/4"	1.562	425
7011	25.31	12.81	8.44	4.06	6" FLG	7.38	9.00	7.17	16.75	19.50	26.13	8.50	21.06	14.00	11.00	11.00	18.00	11.00	23.25	3.50	14.50	2.38	3/4"	1.562	555
7018	32.31	16.31	11.94		8" FLG	10.88			23.75	19.50	26.13	8.50	21.06	14.00	11.00	11.00	18.00	11.00	23.25	3.50	14.50	2.38	3/4"	1.562	675

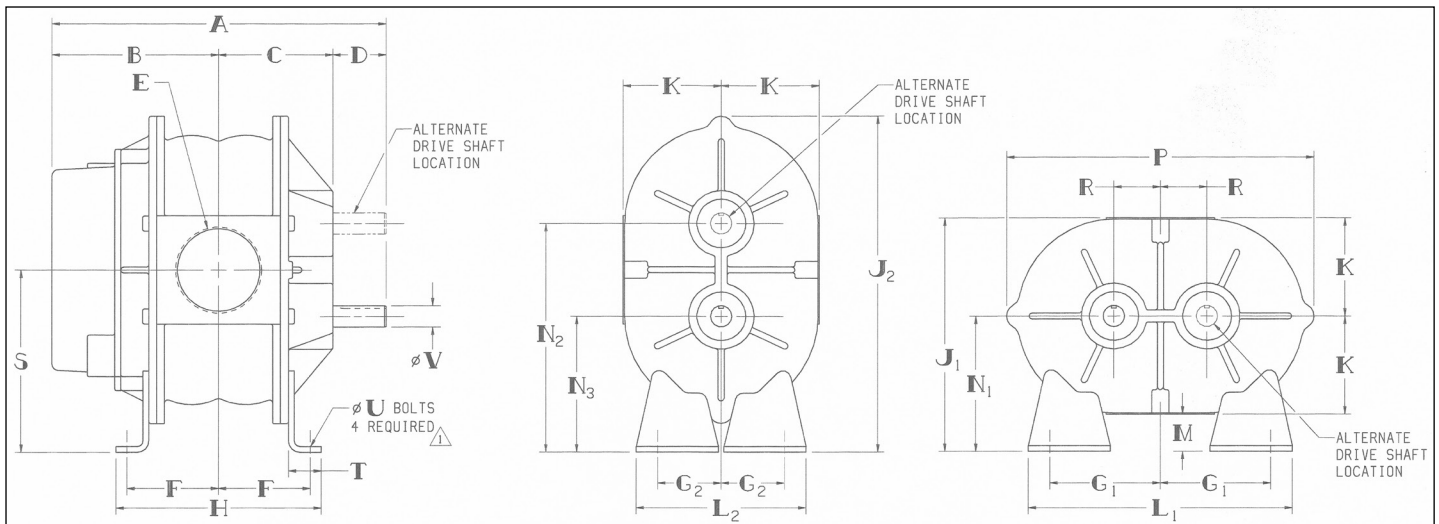

Dimensions: Splash Lube Models/7

Model Size	A	B	C	D	E	F	G1	G2	H	J1	J2	K	L1	L2	M	N1	N2	N3	P	R	S	T	U	V	Weight (lbs.)
3002	11.50	5.69	3.75		1½" NPT	2.63			6.75																82
3003	12.38	6.13	4.19	2.06	2" NPT	3.00	2.68	2.69	7.63	8.94	12.81	3.94	7.25	7.25	1.06	5.00	8.50	5.00	12.19	1.75	6.75	1.75	¾"	.875	88
3006	14.75	7.31	5.38		2½" NPT	4.30			10.00																120
4002	12.94	6.25	3.94		1½" NPT	2.75			7.25																102
4005	15.69	7.63	5.31	2.75	2½" NPT	4.13	3.07	3.07	10.00	10.63	15.13	4.38	8.00	8.00	1.88	6.25	10.25	6.25	13.69	2.00	8.25	2.00	½"	.875	127
4007	17.44	8.50	6.19		3" NPT	5.00			11.75																146
5003	15.25	7.38	4.81		2½" NPT	3.50			8.44																161
5006	17.88	8.69	6.13	3.06	4" NPT	4.81	3.50	3.50	11.06	12.13	17.38	5.38	10.50	10.50	1.38	6.75	11.25	6.25	17.19	2.50	8.75	1.88	⅝"	1.125	196
5009	20.88	10.19	7.63		4" NPT	6.25			14.06																235
6005	18.06	9.38	5.63		3" NPT	4.25			10.00	15.00		6.25													255
6008	21.06	10.88	7.13	3.69	5" NPT	5.75	4.13	4.06	13.00	15.00	21.69	6.25	17.06	11.00	2.50	8.75	14.75	8.75	19.81	3.00	11.75	2.13	¾"	1.375	315
6015	28.06	14.38	10.63		6" FLG	10.88	7.13		20.00	16.25		7.50													461

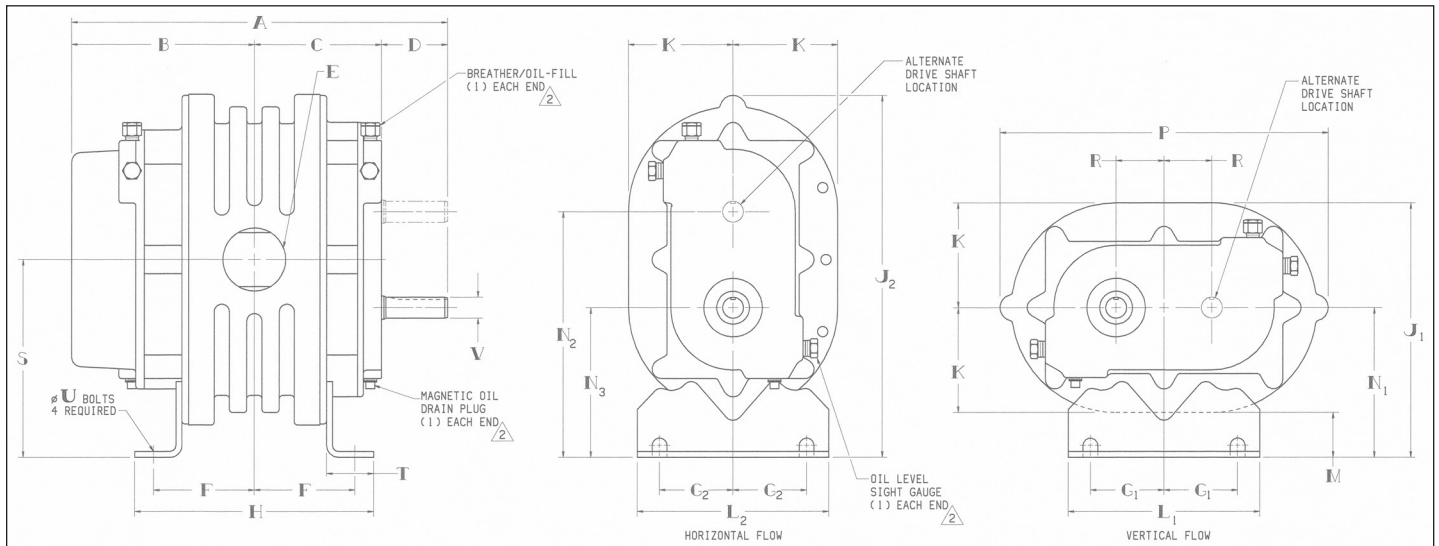

Values shown are approximate and should not be used for construction. Certified drawings are available through your local M-D Pneumatics Sales Professional.

The tri-lobe CP Series units have a cast-in noise reduction on the discharge port. This will reduce the sound level of the blower 3-5dB, or by half.

CONTACT US

For more information, contact your Regional Sales Manager or call us at:

1-800-825-6937

Your Local Sales Professional:



Connect with us online:

www.nwflowtech.com
info@nwflowtech.com

Northwest Flow Technologies | Engineering Services

W. Washington: (253) 740-0530 | E. Washington: (509) 949-3368

Idaho & Montana: (208) 360-3833 | Oregon: (503) 708-9609