

Models

KTC-21 KTC-60 KTC-112

Features

- High pumping speed at pressures below 10 microns; much lower than attainable with single stage pumps
- Ultimate Vacuum: 0.2 microns (McLeod Gauge)
- Positive pressure lubrication assures operation at any pressure up to atmospheric pressure
- No metal-to-metal contact in pumping chamber
- Unequaled durability, even in dirty applications
- Triplex piston design for quiet, vibration-free operation



Specifications

	UNIT	MODEL		
		KTC-21	KTC-60	KTC-112
Nominal Displacement at Rated RPM	CFM / <i>m³/h</i>	21 / 36	60 / 102	107 / 182
Motor	HP / <i>kW</i>	1.5 / 1.1	3 / 2.2	7.5 / 5.6
Motor Speed	RPM	1725	960	1060
Cooling Water Required	GPM / <i>L/min</i>	—	—	1.5 / 5.7
Oil Capacity	Quarts / <i>Liters</i>	2.0 / 1.9	8.0 / 7.6	16.0 / 15.1
Pump Weight	Lbs. / <i>kg</i>	190 / 86	515 / 234	880 / 399
Maximum Gas Ballast Flow	%	10	10	10
Gas Ballast Pressure	Torr (mm Hg abs.)	.020	.020	.020
Ultimate Pressure	Microns	.2	.2	.2
Noise Level at 0.1 Torr	dB(A)	72	70	70

Typical Pumping Speed Curves

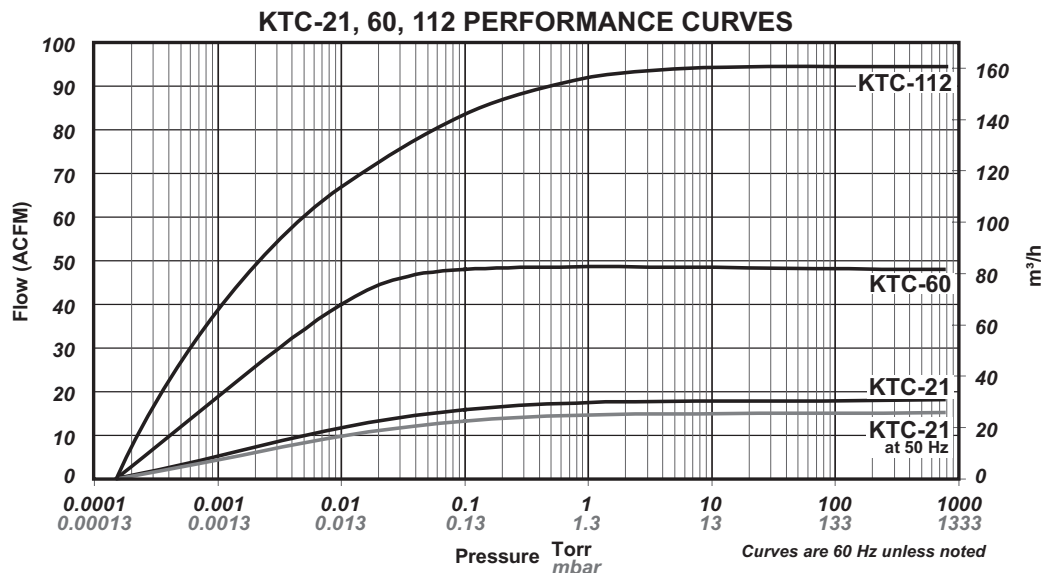

Dimensions

Values shown are approximate and should not be used for construction.
 Certified drawings are available through your local Tuthill Vacuum & Blower Systems Sales Professional.

Models KTC-21

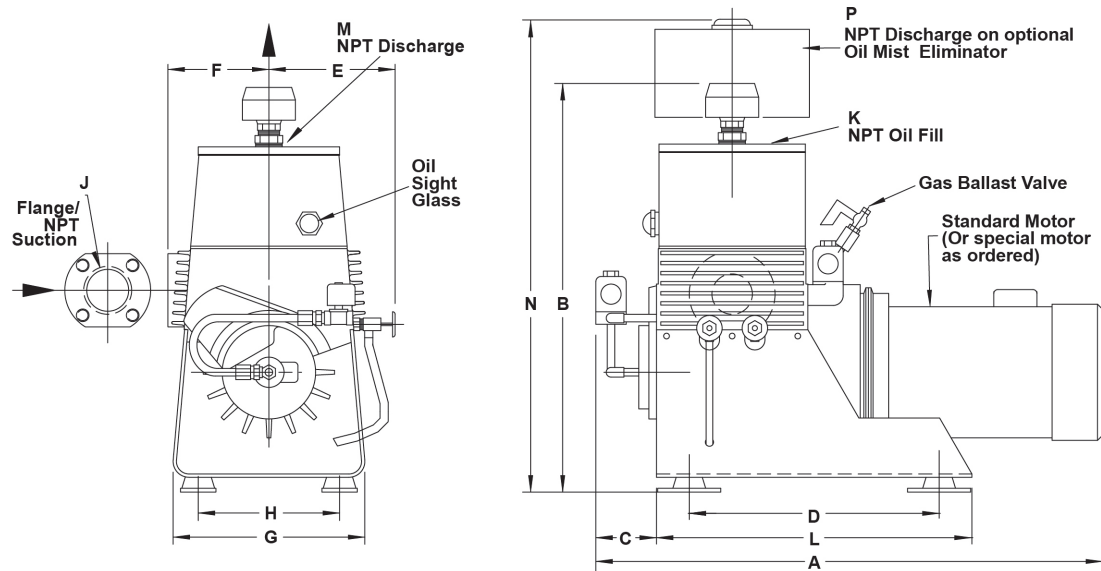

in. mm	A	B	C	D	E	F	G	H	J	K	L	M	N	P	Weight lbs / kg
KTC-21	25.13 638	20.25 515	3.00 76	12.38 314	6.25 159	5 127	9.5 241	7 175	1 1/4" FLG 2" NPT	1" NPT	15.63 397	3/4" NPT	23.44 595	1 1/2" NPT	190 86

Models KTC-30, KTC-112

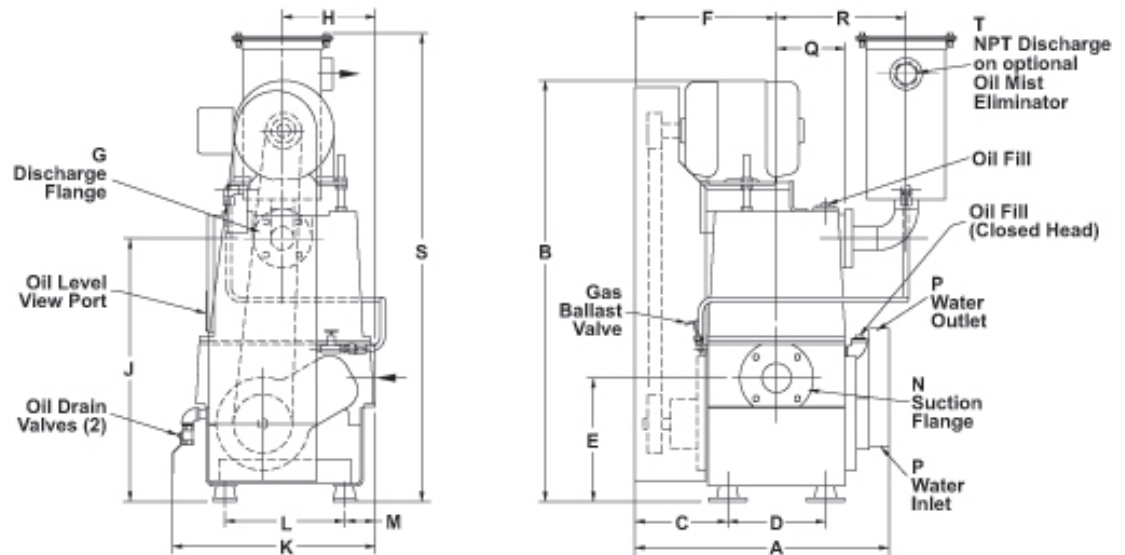

in. mm	A	B	C	D	E	F	G	H	J	K	L	M	N	P	Q	R	S	T	Weight lbs / kg
KTC-60	23.69 602	36.50 927	8.19 208	10 254	19.63 498	13.19 335	1 1/4" FLG 8 203	21.44 545	19.7 500	11.50 292	2.25 57	3" FLG	—	6.19 157	11.50 292	38.44 976	1 1/2" NPT	515 234	
KTC-112	26 660	44.25 1124	9.5 241	10 254	14 356	14.50 368	2" FLG 9.50 241	28.25 718	20.75 527	12.25 311	3.13 79	3" FLG	1/4" NPT	7.25 184	13.25 337	48.88 1242	2" NPT	880 399	

Your Local Tuthill Vacuum Blower Systems Sales Professional:



Western Washington: 253-740-0530
 Eastern Washington: 509-949-3368
 Idaho & Montana: 208-360-3833
 Oregon: 503-708-9609
info@nwflowtech.com



Tuthill Vacuum & Blower Systems
 4840 West Kearney Street
 Springfield, Missouri USA 65803-8702
 o 417.865.8715 800.825.6937 f 417.865.2950
tuthillvacuumblower.com

