

Atlas Copco

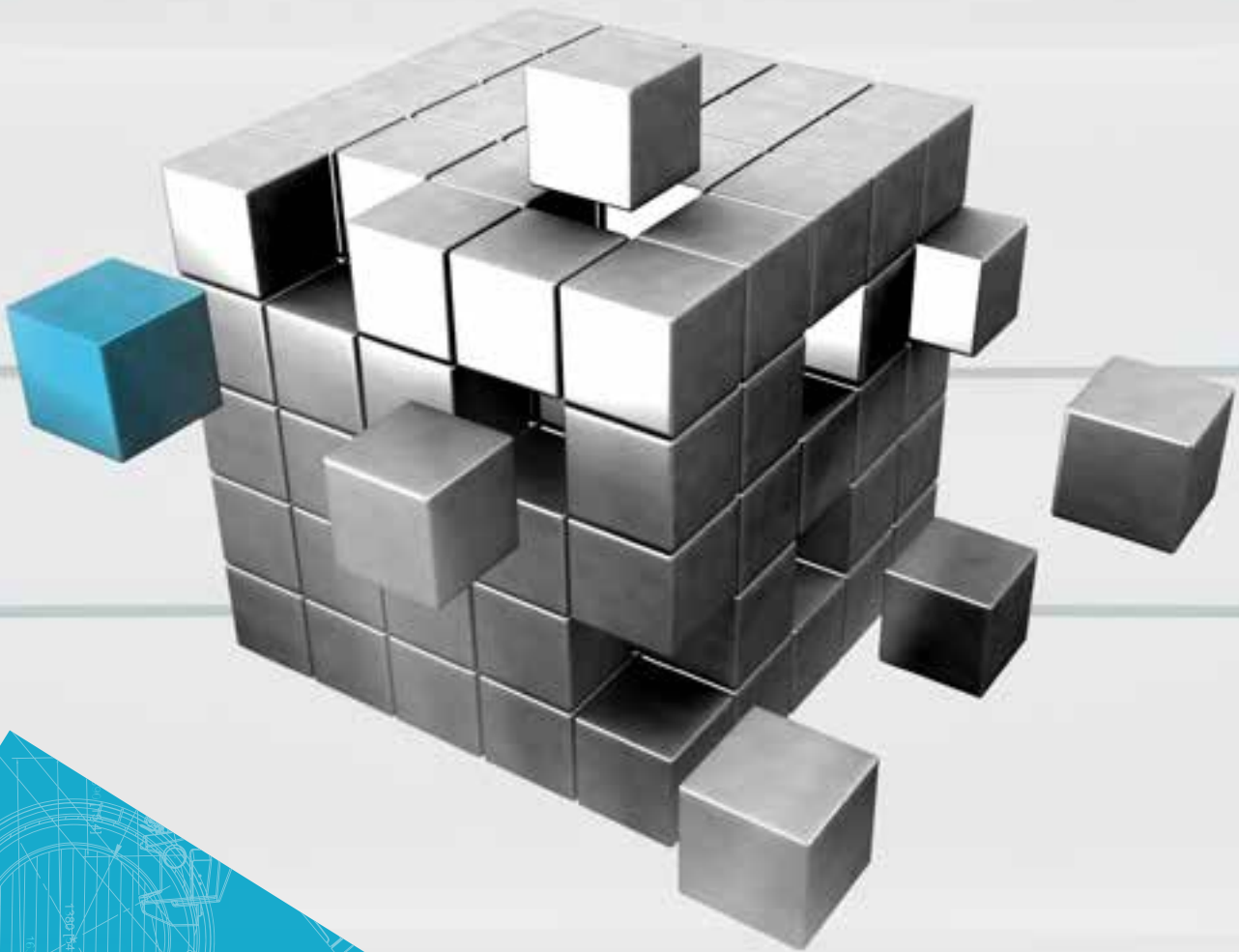

Clean.  
Clever. Compact.

DHS 065-200 VSD+  
Dry Screw  
vacuum pump



# + is more: More clean, more clever, more compact -

## There is always a better way.

Atlas Copco vacuum solutions have gone from strength to strength over the past few years. Building on a strong legacy of innovation in compression technologies, Atlas Copco's vacuum engineers and designers are always seeking to introduce newer technologies and revolutionize productivity for industrial markets across the globe.

Being the vacuum leader, what we want to achieve for you are lower lifecycle costs, higher productivity, less energy consumption, proven and simple operation, and control and easy maintenance. We introduce the DHS 065-200 VSD+ dry screw vacuum pump – Clean. Compact. Clever.



### Clean

The DHS 065-200 VSD+ is a truly clean vacuum pump, visually and audibly.

As a Class 0 certified pump, it needs no oil and its noise-reducing canopy ensures a quiet operation. You can expect superior performance with excellent vapor and dust handling capabilities. The simple yet effective design and internal parts reduces maintenance and system downtimes.



### Clever

The new screw profile of the DHS 065-200 VSD+ offers best-in-class performance in its category. Equipped and controlled with the MKV Elektronikon®, the pump offers unrivalled built-in intelligence. Elektronikon® is a state-of-the-art monitoring system which can integrate your plant management system, thanks to a remote monitoring option. The Variable Speed Drive runs only when required and offering you not just savings but true peace of mind.

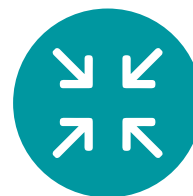

### Compact

The compact footprint of the DHS VSD+ ensures a quick and trouble-free installation. This is a truly plug and play pump. Just connect the process to the inlet valve and the pump is ready to start.



# Creating a safer, cleaner and smarter industrial environment

The DHS 065-200 VSD+ is a fully air-cooled, compact and clean dry vacuum pump. It's robust design and small footprint makes it the perfect pump for industrial applications.

This innovatively designed pump with remote monitoring and control capabilities is efficient, has a low cost of ownership and is a truly clean vacuum pump.



Bearing Vent



MK5 controller



Belt driven 100% oil free



# Features



## Dry Screw Technology

Each internal part of the DHS VSD<sup>+</sup> is positioned to improve efficiency and reduce maintenance.

With only 50 moving parts and a triple pitch screw design with aluminum element, the DHS VSD<sup>+</sup> is optimized for best-in-class efficiency. The PFPE inert grease-lubricated bearings and the belt are the only parts, which require replacement, with exchange intervals being greater than one year.

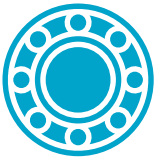

## Bearing Vent

The innovative bearing vent prevents contamination of the grease-lubricated bearings by the inlet gases from the process. The advantage is you get a constant airflow towards the element limiting the ultimate vacuum to 0.1 mbar.



## A Dry Air-Cooled Pump

Certified as Oil-Free "Class 0", the DHS 065-200 VSD<sup>+</sup> is a cool running pump with no water or oil cooling required. The simple air cooled design is integrated into the pump and provides minimal heat load in the environment. It is simple and low-cost, minimizing the overall cost as the air-cooling eliminates the need for oil or water changes.

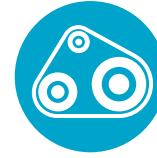

## Belt Drive

You would think this is old-school, but it is actually the apt technology for this clean pump. The belt transmission operates on a soft start which produces less stress on the belt and increases its lifetime. Easy to maintain, a technician can change the belt within 30 minutes.



## Noise Reducing Canopy

The DHS 065-200 VSD<sup>+</sup> is a machine with a small footprint housed in a noise reducing and vibration-free canopy. The compact design is built to reduce noise levels, yet retain the integrity of the parts within the pump. The canopy can be removed easily for maintenance access. This also greatly reduces installation complexity costs for a true Plug and Play pump.



## Built-in Intelligence

The Elektronikon<sup>®</sup> monitoring system is built-in, comprehensive monitoring system that offers you remote control and monitoring of your pump. Get the latest status updates on running and stopped hours, programmable timers, warning, fault and shutdown indications, etc.

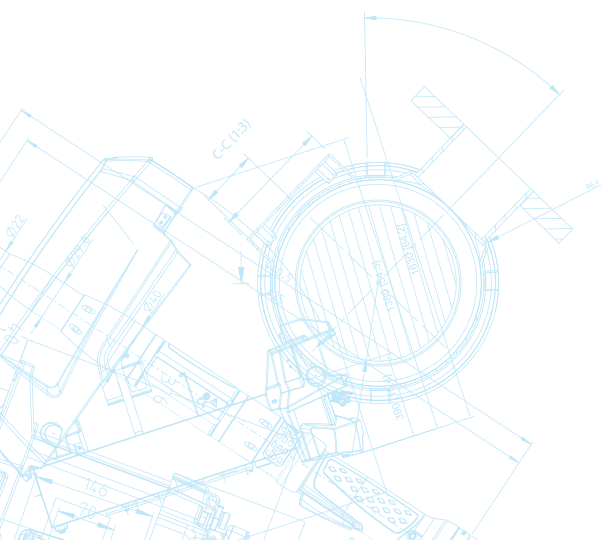

# Applications

- Pick and Place
- Cleaning and Drying
- Food Packaging
- Vacuum Bagging
- Vacuum-aided drying
- Paper Converting
- Holding
- Corrugated Cardboard Manufacturing



## Technical specifications

	DHS 065 VSD <sup>+</sup>	DHS 100 VSD <sup>+</sup>	DHS 160 VSD <sup>+</sup>	DHS 200 VSD <sup>+</sup>
Nominal pumping speed (m <sup>3</sup> /h)	65	100	160	200
Nominal pumping speed (ACFM)	38	59	94	118
Ultimate vacuum level mbar(a)	1	1	1	1
Ultimate vacuum level Torr	0.75	0.75	0.75	0.75
Nominal motor power (kW)	1.5	2.2	3	4
Nominal motor power (HP)	2	3	4	5
Noise level dB(A)	64	65	69	71
Inlet	2"	2"	2"	2"
Outlet	1 ½"	1 ½"	1 ½"	1 ½"

NPT adapters included as standard

## Performance curves

DHS 065 and 100 VSD<sup>+</sup>

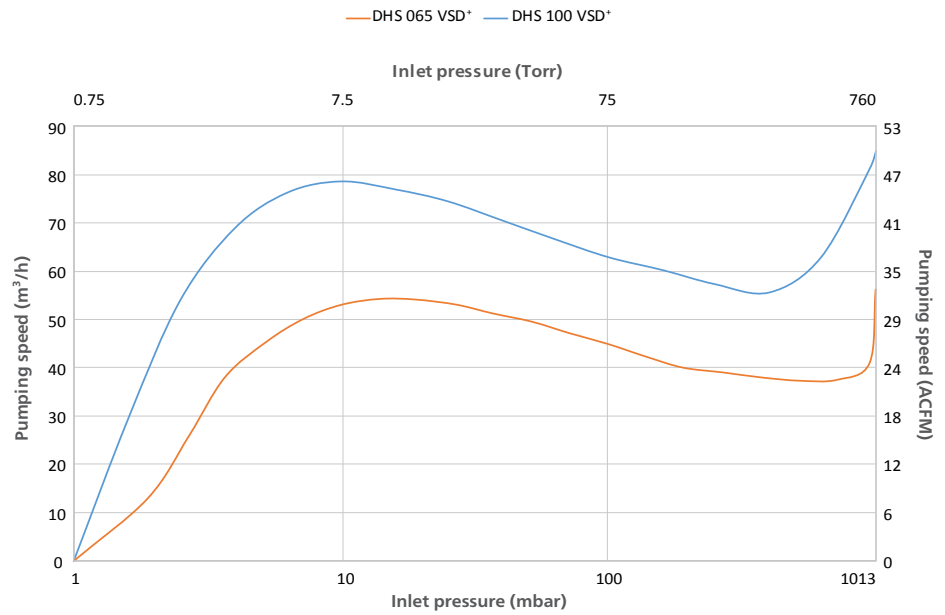

DHS 160 and 200 VSD<sup>+</sup>

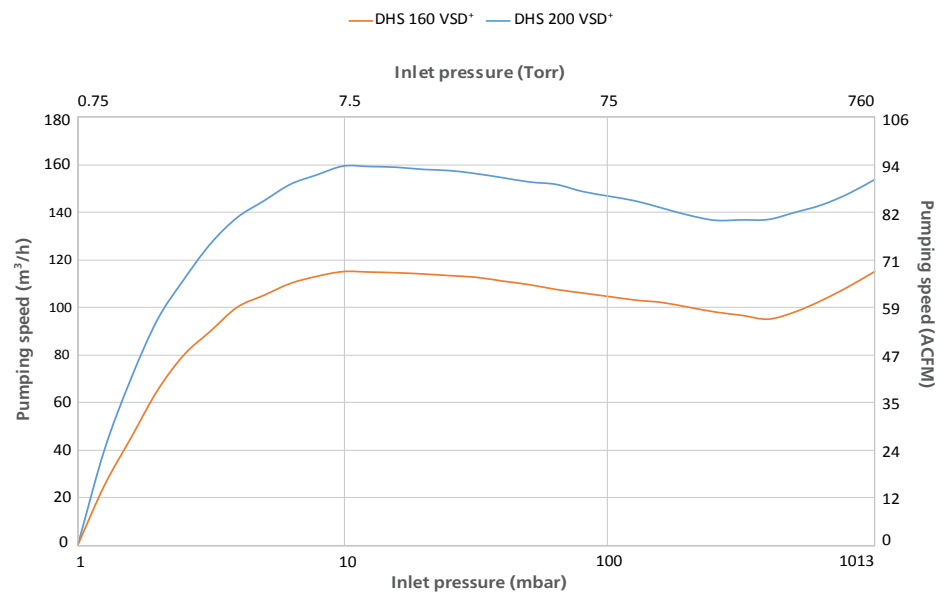

## Dimensions

Variable Dimensions			
Model	Length (mm) [inch]	Width (mm) [inch]	Height (mm) [inch]
DHS 065 VSD <sup>+</sup>	800 [31.5"]	577 [22.7"]	365 [14.4"]
DHS 100 VSD <sup>+</sup>	800 [31.5"]	577 [22.7"]	365 [14.4"]
DHS 160 VSD <sup>+</sup>	1000 [39.4"]	577 [22.7"]	365 [14.4"]
DHS 200 VSD <sup>+</sup>	1000 [39.4"]	577 [22.7"]	365 [14.4"]



All dimensions in mm [inch]

