

DRDP & DRSP Pump Packages

Features

- Completely self contained
- Designed for long life
- Insensitive to contamination
- Easy to install and maintain
- Fully assembled and wired

Kinney® Duplex and Simplex Liquid Ring Vacuum Pump Systems are fully assembled with all interconnecting wiring and piping. Systems are mounted on a common steel base and fully tested and painted before shipment. They consist of duplex or simplex compound liquid ring vacuum pumps and the following system components:

- 304 stainless steel exhaust separator tanks
- Vacuum gauges
- Vacuum relief valves
- Suction line check valves
- Suction line pump isolation valves
- Adjustable vacuum control switches
- Motor control center with magnetic motor starter, HOA switches, fusible disconnect switches, and an automatic pump alternator
- Cooling water valves, strainers and thermometers
- Seal water heat exchangers
- Drive motors TEFC
- Seal water thermometers and valves
- Inlet flexible connector

Specifications

DRSP SIMPLEX MODELS	75	100	125	200	300	525	526
Rotational Speed RPM	1750	1750	1750	1750	1750	1750	1500
Standard Motor* HP	5	7.5	10	15	25	50	40
60oF Cooling Water Required GPM	10	12	14	20	28	48	32
Cooling Water Connection NPT	1	1	1	1	1.5	2	2
Inlet/Outlet Connections Inches	1.5	1.5	1.5	2	2	3	3

DRDP DUPLEX MODELS	75	100	125	200	300	525	526
Rotational Speed RPM	1750	1750	1750	1750	1750	1750	1500
Standard Motor* HP	5	7.5	10	15	25	50	40
60oF Cooling Water Required GPM	20	24	28	40	56	96	64
Cooling Water Connection NPT	1	1	1	1	1.5	2	2
Inlet/Outlet Connections Inches	1.5	2	2	3	3	4	4

*Standard motor is open, drip proof for standard operating conditions. Smaller or larger motors may be used on some models when chosen sealant system and/or operating conditions permit.

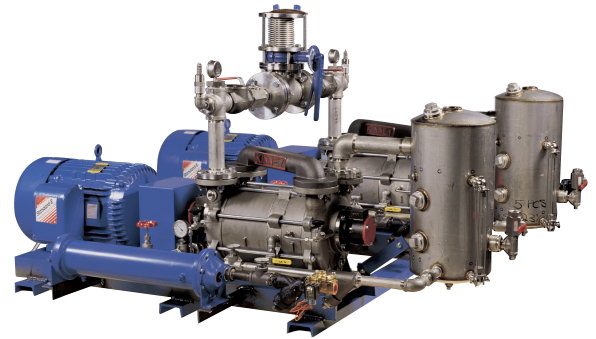

Optional all stainless steel package shown. Control panel not shown.

Optional Accessories

- Circulating pump
- Seal water level controls
- Custom electrical controls
- Receiver tanks
- All stainless steel package

DRSP Performance Data**

Typical Pumping Capacity in ACFM of Air (50% relative humidity, cooling water inlet temperature 60°F, barometric pressure 14.696 PSIA)

Pressure mm Hg abs	Vacuum inches Hg	75	100	125	200	300	525	526
760	0	60	70	95	150	160	350	320
632	5	63	70	95	162	180	380	340
507	10	65	73	98	174	210	420	360
380	15	67	77	103	185	245	460	380
254	20	68	85	114	200	280	510	420
126	25	70	100	130	205	300	560	430
100	26	67	95	125	190	275	515	400
74	27	60	85	115	175	260	480	350
49	28	50	80	100	145	205	385	275
30	28.8	20	35	45	70	90	155	100

**For DRSP performance data, multiply DRSP specifications by 2.

DRDP Dimensions (Inches)

Model	Length	Width	Height
75	50	65	43
100	73	60	48
125	73	60	48
200	82	72	52
300	82	72	52
525	100	90	60
526*	84	128	60

*Belt-driven

DRSP Dimensions (Inches)

Model	Length	Width	Height
75	50	32	40
100	73	27	40
125	73	27	40
200	82	33	46
300	82	33	46
525	100	41	60
526*	84	60	60

*Belt-driven

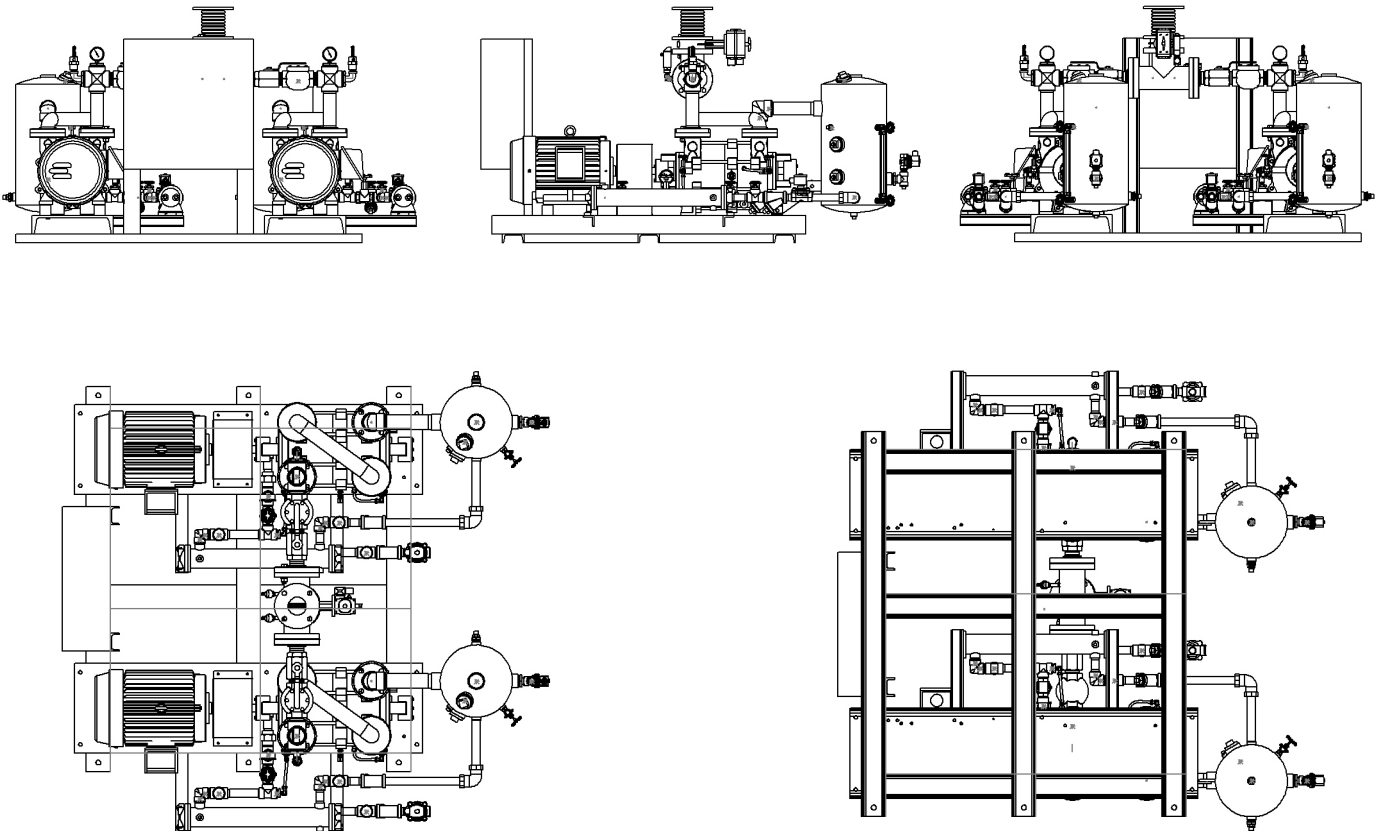

Your Local Tuthill Vacuum Blower Systems Sales Professional:



Western Washington: 253-740-0530

Eastern Washington: 509-949-3368

Idaho & Montana: 208-360-3833

Oregon: 503-708-9609

info@nwflowtech.com



Tuthill Vacuum & Blower Systems

4840 West Kearney Street

Springfield, Missouri USA 65803-8702

o 417.865.8715 800.825.6937 f 417.865.2950

tuthillvacuumblower.com



TH-092 01/17